

IOM manual

tapflo®

Aseptic EHEDG Diaphragm Pumps

Original instruction
2022 | 1



Read this instruction manual carefully,
before you install and operate the pump



Pump models:

TX94

TX144

TX244

TX444



» All about your flow™

www.tapflo.com

CONTENTS

EC DECLARATION OF CONFORMITY 01/EC/EHE/2022	5
EU DECLARATION OF CONFORMITY 01/ATEX/AODD/2022	6
0. GENERAL	7
0.1. Introduction	7
0.2. Warning symbols	7
0.3. Qualification and training of personnel	7
0.4. EHEDG certification	7
1. INSTALLATION	8
1.1. Operation principle	8
1.2. Receiving inspection	8
1.3. Lifting and transportation	9
1.4. Storage	9
1.5. Foundation	9
1.6. Suction and discharge piping	10
1.6.1. Connection of suction pipe	10
1.6.2. Connection of discharge pipe	10
1.6.3. EHEDG process connections and sealings	10
1.6.4. Optimizing the pipework layout for drainability	10
1.7. Health and safety	11
1.7.1. Protection	11
1.7.2. Explosion hazardous environments – ATEX	11
1.7.3. Air pressure	12
1.7.4. Noise level	12
1.7.5. Temperature hazards	13
1.8. Air connection	13
1.8.1. Air treatment system	13
1.9. Example of installation	14
1.10. Recommended installations	14
1.10.1. Flooded	14
1.10.2. Self-priming	14
2. OPERATION	15
2.1. Before starting the pump	15
2.2. Starting and operation	15
2.2.1. Dry running	15
2.2.2. Optimization of the pump lifetime	15
2.3. Pump stopping	16

CONTENTS

2.4.	Residual risks	16
2.5.	Disposal after expiration of the expected lifetime	16
2.6.	Actions in emergency	16
2.7.	Cleaning of the pump	17
2.7.1.	CIP and SIP.....	17
2.7.1.1.	Drainage of the pump TX94 – TX444	17
2.7.1.2.	Limited possibility of draining the pump	17
3.	MAINTENANCE	18
3.1.	When the pump is new or reassembled	18
3.1.1.	Performance test.....	18
3.2.	Routine inspection	18
3.3.	Complete inspection	18
3.4.	Location of faults	19
3.5.	TX94-TX444 – Disassembly of the pump	20
3.5.1.	Before the disassembly procedure	20
3.5.2.	Disassembly video.....	20
3.5.3.	Disassembly procedure.....	20
3.6.	TX94-TX444 – assembly of the pump	24
3.6.1.	Assembly video	24
3.6.2.	Assembly procedure	24
3.6.3.	Test run	25
4.	OPTIONS	26
4.1.	Magnetic ball lifters.....	26
5.	SPARE PARTS.....	27
5.1.	TX94 – Spare parts drawing	27
5.2.	TX94 – Spare parts list	28
5.3.	TX94 – Spare parts options	29
5.4.	TX144-TX444 – Spare parts drawing	30
5.5.	TX144-TX444 – Spare parts list.....	31
5.6.	TX144 – TX444 – Spare parts options.....	32
5.7.	Stocking recommendation	33
5.8.	How to order parts.....	33
5.9.	Pump code.....	34
6.	DATA	35
6.1.	Capacity curves.....	35
6.2.	Capacity changes.....	35

CONTENTS

6.3.	Dimensions	36
6.4.	Technical data	37
6.5.	Tightening torques	37
6.6.	Permitted loads on manifolds.....	38
7.	WARRANTY	39
7.1.	Warranty form.....	39
7.2.	Returning parts	40
7.3.	Warranty	40

EC DECLARATION OF CONFORMITY 01/EC/EHE/2022

Series:

T(...)94...; T(...)144...; T(...)244...; T(...)444...;

Manufactured by Tapflo Sp. z o.o., Poland for:

Tapflo Group AB

Filaregatan 4

442 34 Kungälv, Sweden

This declaration of conformity is issued under the sole responsibility of the manufacturer.

Object of declaration: **ASEPTIC AIR OPERATED DIAPHRAGM PUMPS**

The object of the declaration described above is in conformity with the relevant Union harmonisation legislation:

- Directive 2006/42/EC of European Parliament and of the Council of 17 May 2006 on machinery, amending Directive 95/16/EC;

Mr Michał Śmigiel is authorized to compile the technical file.

Tapflo Sp. z o.o., Poland

ul. Czatkowska 4b

83-110 Tczew



Signed for and on behalf of Tapflo Group AB

A handwritten signature in black ink, appearing to read 'Per Antonsson', written over a white background.

Per Antonsson

Chief Executive Officer

Kungälv, 16.12.2022

EU DECLARATION OF CONFORMITY 01/ATEX/AODD/2022

Series:

TX(...)9...; TX(...)20...; TX(...)50...; TX(...)100...; TX(...)200...; TX(...)400...; TX(...)800...;
TX(...)25...; TX(...)70...; TX(...)120...; TX(...)220...; TX(...)420...; TX(...)820...;
TX(...)30...; TX(...)80...; TX(...)125...; TX(...)225...; TX(...)425...; TX(...)825...;
TX(...)94...; TX(...)144...; TX(...)244...; TX(...)444...;

Manufactured by Tapflo Sp. z o.o., Poland for:

Tapflo Group AB

Filaregatan 4

442 34 Kungälv, Sweden

This declaration of conformity is issued under the sole responsibility of the manufacturer.

Object of declaration: **CONDUCTIVE AIR OPERATED DIAPHRAGM PUMPS DESIGNED FOR USE IN POTENTIALLY EXPLOSIVE ATMOSPHERES**



The object of the declaration described above is in conformity with the relevant Union harmonisation legislation:

- Directive **2006/42/EC** of European Parliament and of the Council of 17 May 2006 on machinery
- Directive **2014/34/EU** of the European parliament and of the council of 26 February 2014 on Equipment or Protective System intended for use in potentially explosive atmospheres

Applied harmonised standards:

- **EN ISO 80079-36:2016-07**
- **EN ISO 80079-37:2016-07**

ATEX marking:

  **II 2G Ex h IIC T6...T4 Gb**
II 2D Ex h IIIC T54°C...T124°C Db

Notified body **J.S. Hamilton Poland Sp. z o.o.** performed **type examination** and issued certificate **JSHP 19 ATEX 0018X**.

Signed for and on behalf of Tapflo Group AB



Per Antonsson
Chief Executive Officer
Kungälv, 16.12.2022

0. GENERAL

0. GENERAL

0.1. Introduction

The Tapflo Air Operated Diaphragm Aseptic Pump range meet most demanding requirements of European Hygienic Engineering and Design Group, devoted to the advancement of hygienic design. Unique pump design allows pumped liquid to be completely drained whereby germs grow is reduced to minimum. The pumps are designed to be safe, simple and easy to use and maintain. The construction is seal-less and without rotating parts. The pumps are suitable for a variety of duties in hygienic installations.

With proper attention to maintenance, Tapflo Pumps will give efficient and trouble free operation. This instruction manual will familiarise operators with detailed information about installing, operating and maintaining of the pump.

0.2. Warning symbols

The following warning symbols are present in this instruction manual. This is what they say:



This symbol stands next to all safety instructions in this instruction manual where danger to life and limb may occur. Observe these instructions and proceed with utmost caution in these situations. Inform also other users of all safety instructions. In addition to the instructions in this instruction manual, the general safety and accident prevention regulations must be observed.



This signal stands at points in this instruction manual of particular importance for compliance with regulations and directives, for correct work flow and for the prevention of damage to and destruction of the complete dampener or its subassemblies.

0.3. Qualification and training of personnel



The personnel in charge of installation, operation and maintenance of the pumps we produce must be qualified to carry out the operations described in this manual. Tapflo shall not be held responsible for the training level of personnel and for the fact that they are not fully aware of the contents of this manual. In case any instructions in this manual are unclear or any information is lacking, please contact Tapflo before handling the pump.

0.4. EHEDG certification

The Tapflo Aseptic series is EHEDG certified by the Danish Technological Institute. The EHEDG certification comprise both a hygienic design evaluation as well as CIP cleanability tests. Our first aseptic pump was certified in 2004.



1. INSTALLATION

1. INSTALLATION

1.1. Operation principle

The Tapflo diaphragm pump is driven by compressed air. The two diaphragms are connected by a diaphragm shaft and pushed back and forth by alternately pressurising the air chambers behind the diaphragms using an automatically cycling air valve system.

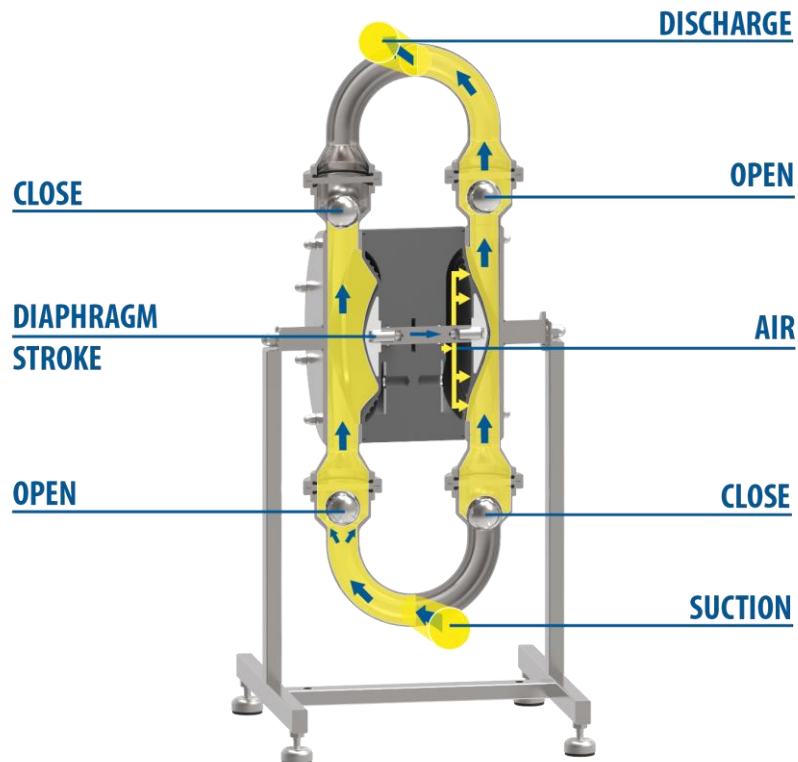

Pump cycle:

➤ **Suction**

One diaphragm creates a suction action in one chamber (on the right) when being pulled back from the housing.

➤ **Discharge**

The other diaphragm simultaneously transmits the air pressure to the liquid in the second chamber (on the right) of the housing, pushing it towards the discharge port.

During each cycle the air pressure on the back of the discharging diaphragm is equal to the head pressure on the liquid side. Tapflo diaphragm pumps can therefore be operated against a closed discharge valve with no negative effect to the life of the diaphragms.

1.2. Receiving inspection

Although precaution is taken by us when packing and shipping, we urge you to carefully check the shipment on receipt. Make sure that all parts and accessories listed on the packing list are accounted for. Immediately report any damage or shortage to the transport company and to us.

1. INSTALLATION

1.3. Lifting and transportation



Before handling the pump check the weight of the pump (see 6.4. "Technical data"). Refer to Your local standards on how to handle the pump. If the weight is excessive to transport by hand it must be lifted using slings and a suitable lifting device e.g. a crane or forklift. Always use at least two slings and make sure they are secured in such a way to prevent the pump from slipping and that the pump unit is hanging straight.

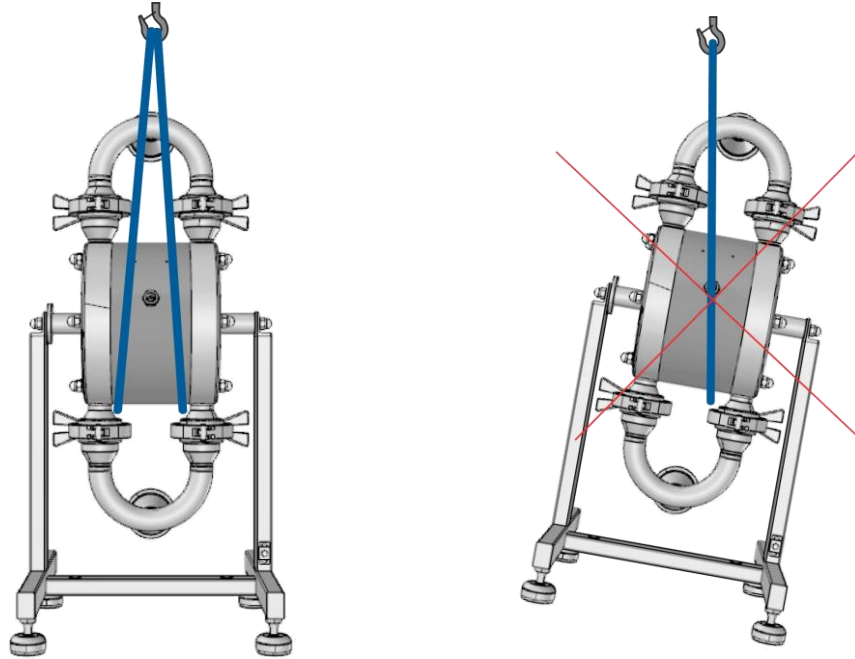

- Never lift the pump under pressure.
- Be careful that nobody passes under the pump when lifted.
- Never try to lift the pump by the manifolds or hoses attached to the pump.
- As an option pumps can be equipped with lifting eyebolts connected with the pump pin screws

1.4. Storage



If the equipment is to be stored prior to installation, place it in a clean location. The pump should be stored in an ambient temperature of 15°C (59°F) to 25°C (77°F) and relative humidity below 65%. It should not be exposed to any heat source e.g. radiator, sun as this could result in a negative way on the tightness of the pump. Do not remove the protective covers from the suction, discharge and air connections which have been fastened to keep pump internals free of debris. Clean the pump thoroughly before installation.

1.5. Foundation



The support of the pump is furnished with mounting holes. Fix the pump on a stable foundation, which is able to absorb vibrations. It is essential for the operation of the pump to mount the pump with the feet in a downward direction (see sketch in chapter 1.9. "Example of installation")

1. INSTALLATION

1.6. Suction and discharge piping



Suction and discharge piping should be fully supported and anchored near to but independent of the pump. The piping to the pump should be a hose, to prevent undue stress and strain on the pump connections and the piping.

1.6.1. Connection of suction pipe

Remember that the suction pipe/connection is the most critical point, especially if the pump is priming. Just a small leakage will dramatically reduce the suction capability of the pump. When connecting the suction pipe, following is recommended.

- 1) For satisfactory operation, use reinforced hose (the suction power may otherwise shrink the hose) or other flexible piping. The internal diameter of the hose should be the same as on the suction connection (at the bottom of the pump) to have best suction capability. If the diameter of a hose is smaller, it will affect the pump's performance or cause its malfunction.
- 2) Make sure that the connection hose - pump is completely tight, otherwise the suction capability will be reduced.
- 3) Always use as short suction pipe as possible. Avoid air pockets which can arise with long piping.

1.6.2. Connection of discharge pipe

For this connection it is only recommended a simple and positive flow connection. Use a hose or flexible piping (minimum one meter) between the discharge connection and any rigid fixed piping. Coil the hose at least one turn. All components (hose, pipe, valves etc.) on the discharge piping must be designed for minimum PN 10.

1.6.3. EHEDG process connections and sealings

EHEDG analysed both aseptic and non-aseptic process connections and pipe couplings in terms of EHEDG design guidelines. As a result "EHEDG Position Paper" was issued, where certain allowed connection types and its sealings are listed. The document can be download from EHEDG official website. For more information contact us.

1.6.4. Optimizing the pipework layout for drainability

The pump is designed to follow the EHEDG requirements, where one of the most important factors is the drainability. Apart from the pump it is also important that the whole pipe system is drainable. Horizontal surfaces must be avoided, as a general rule pipes should slope at least 3°.

1. INSTALLATION

1.7. Health and safety

The pump must be installed according to local and national safety rules.



The pumps are constructed for particular applications. Do not use the pump on applications different from that for which it was sold without consulting us to ascertain its suitability.



The pumps are tested with water. If the pumped product can come into reaction with water, please make sure the pump is dry before putting it into operation

1.7.1. Protection



In the interest of health and safety it is essential to wear protective clothing and safety goggles when operating, and/or working in the vicinity of Tapflo pumps.

1.7.2. Explosion hazardous environments – ATEX



The "TX" Aseptic EHEDG series pumps are designed to operate in environments where there is danger of explosion. Follow below instructions and local/national rules for safe use. The special non-ATEX execution ("T" Aseptic EHEDG series) available upon request.

ATEX (directive 2014/34/EU) classification of Tapflo TX pumps:

II 2G Ex h IIC T6...T4 Gb

II 2D Ex h IIIC T54°C...T124°C Db

Equipment group:	II – all other explosive areas than mines;
Category group:	2 – high level of protection (can be used in zone 1);
Atmosphere:	G – gas; D – dust;
Explosion group:	IIC – gas group (such as acetylene, hydrogen); IIIC – dust group (conductive dusts);
Type of protection:	h – control of ignition sources;
Temperature class:	T4, T6 – in the event of a malfunction, the maximum temperature of a surface that may be exposed to gas T4 = 135°C, T6 = 85°C;
EPL protection level:	Gb, Db – high protection.

1. INSTALLATION



Temperature classes and allowable temperatures

The temperature class of the pump depends on the temperature of the pumped medium and ambient temperature. Ambient temperature range depends on pump configuration, follow pump nameplate for allowable range. Contact Tapflo for more information.

Medium temp.	Temperature class / Surface temperature	Temperature class / Surface temperature	Temperature class / Surface temperature
	$-20^{\circ}\text{C} \leq T_a \leq +40^{\circ}\text{C}$	$-20^{\circ}\text{C} \leq T_a \leq +50^{\circ}\text{C}$	$-20^{\circ}\text{C} \leq T_a \leq +60^{\circ}\text{C}$
40°C	T6 / T54°C	T6 / T64°C	T6 / T74°C
50°C	T6 / T64°C	T6 / T64°C	T6 / T74°C
60°C	T6 / T74°C	T6 / T74°C	T6 / T74°C
70°C	T6 / T84°C	T6 / T84°C	T6 / T84°C
80°C	T5 / T94°C	T5 / T94°C	T5 / T94°C
90°C	T4 / T104°C	T4 / T104°C	T4 / T104°C
100°C	T4 / T114°C	T4 / T114°C	T4 / T114°C
110°C	T4 / T124°C	T4 / T124°C	T4 / T124°C



Earth connection of the pump and other equipment

Connect a suitable earth wire to the stainless steel earth connection that is placed on the pump stand. Connect the other end of the earth wire to earth and also make sure that other equipment like hoses/pipes/containers etc. are properly earthed/connected.



Antistatic surface

Pumps in ATEX execution should be cleaned in order to preserve antistatic properties. Layer of dust or other solid particles on the outer surfaces is unacceptable

Dry run

ATEX approved pumps can run dry without increasing the risk of creating potential ignition sources. Nevertheless, dry run periods should be decreased to minimum as they increase the wear of parts inside of the pump. What is more, when running dry (e.g. during self-priming) the pump should run at a low speed controlled via a needle valve.

1.7.3. Air pressure



The maximum air pressure for Tapflo pumps is 8 bar. Higher air pressure than 8 bar can damage the pump and may cause injury to personnel in vicinity of the pump. If you intend to apply a higher air pressure than 8 bar, please consult us.

1.7.4. Noise level



At tests, the noise level from a Tapflo pump has not exceeded 85 dB(A). Under some circumstances, for example if the pump is operating under high air pressure at low discharge head, the noise can be inconvenient or hazardous for personnel staying for long periods in the vicinity of the pump. This hazard can be prevented by:

- using suitable ear protection;
- lowering the air pressure and/or raising the discharge head;
- leading out the outgoing air from the room by connecting a hose to the muffler connection of the pump;

1. INSTALLATION

1.7.5. Temperature hazards



➤ Raised temperature can cause damage on the pump and/or piping and may also be hazardous for personnel in the vicinity of the pump/piping. Avoid quick temperature changes and do not exceed the maximum temperature specified when the pump was ordered. See also general max temperatures based on water in chapter 6. "DATA".



➤ When the pump is exposed to ambient temperature variations or if there is big difference between the temperature of the product and the surrounding, the tightening torques of the housing nuts should be checked periodically as part of preventive maintenance. See chapters 3.2 "Routine inspection", 6.5 "Tightening torques".



➤ If a hot product is pumped, the pump should not stand still when filled for a longer period of time. This could cause leakage from the valves and contamination and/or damage of the air valve.



➤ The fluid remaining in the connected piping, as well as in the pump itself, may expand because of freezing or heat, which may cause damage to the pump or/and piping, and lead to leakage of the fluid.



➤ Below 0°C (32°F) plastic materials become more fragile what can cause accelerated wear of parts made of these materials. This is a hazard that has to be accepted when pumping such cold products. Also in such case, when a pump is not operational it should be drained of all liquid.



➤ Bear in mind that the viscosity of the product changes with temperature. This has to be taken into consideration when selecting the pump.

1.8. Air connection

Screw the air hose into the air intake on the centre block of the pump with for example a bayonet coupling. For best efficiency, use the same hose diameter as the internal diameter of the connection on the air intake.

1.8.1. Air treatment system



The air valve is constructed for oil-free air. Lubrication of the air is **not allowed**. However, if the air is very dry (laboratory air), we recommend to use a plastic air valve. Maximum air pressure is 8 bar. As prevention purpose, a filtration of the air by means of a 5 micron filter or finer is recommended. Recommended air quality according to PN-ISO8573-1:2010 is particles class 6, water class 4 and oil class 4. Dirt in the air can under unfortunate circumstances be the cause of a breakdown. If a compressor used to generate compressed air is not fitted with an air dryer it is recommended to use a water separator to remove the extent of water from the prepared air.

To facilitate the operation of the pump we recommend an air treatment system connected to the air supply. These components should be included:

- 1) Regulator to adjust the air pressure;
- 2) Manometer to read the actual pressure;
- 3) Needle valve to adjust the air flow (especially when operating the pump in the lower range of performance);
- 4) Filter.

These components are included in Tapflo's **Air treatment system** which can be ordered from us.

1. INSTALLATION

1.9. Example of installation

- 1) Gate valve compressed air
- 2) Filter and pressure regulator
- 3) Flexible hose
- 4) Needle valve
- 5) Flexible piping
- 6) Gate valve suction
- 7) Gate valve discharge
- 8) Coiled flexible piping
- 9) Flow gauge

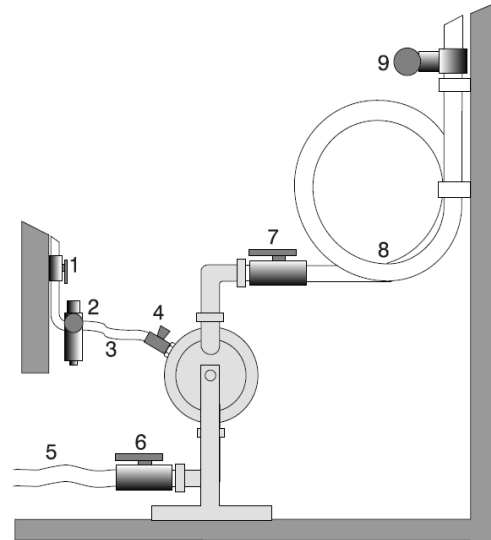

1.10. Recommended installations

The Tapflo pump is flexible in the way you are able to install it.

1.10.1. Flooded



The piping system is designed with a positive suction head. This is the best way of installation where it is necessary to completely evacuate all liquid from the container, or where viscous (thick) products are transferred.

NOTE! Do not exceed 0,7 bar(g) suction pressure! Higher pressure may cause premature diaphragm failure and irregular pump operation.

1.10.2. Self-priming

The Tapflo pump is designed to pull a high vacuum. It is able to evacuate an empty suction pipe without any damage to the pump. The suction lift is up to 5 meters (16.4 ft.) from an empty suction pipe and up to 8 meters (26.2 ft.) from a wetted pipe. The suction capability depends on the pump size (see chapter 6. "DATA").



NOTE!

Even if all above safety instructions are met and complied with, there still exists a minor danger in the event of a leakage or mechanical damage of the pump. In such case the pumped product can emerge on sealing areas and connections.

2. OPERATION

2. OPERATION

2.1. Before starting the pump



- Make sure the pump is installed according to the installation instruction (chapter 1).
- Filling of the pump with liquid before start is not necessary.
- When installation is new or reinstalled, a test run of the pump with water should be conducted to make sure that the pump operates normally and does not leak.



- When installation is new or reinstalled, check the pump housing nuts tightening torque (see chapter 6.5. "Tightening torques"). After approximately one week of operation, the torque should be checked again. This is important to prevent possible leakage.

2.2. Starting and operation

- Open the discharge valve.
- **Note! Considering the suction capacity when air is still in the suction pipe, it is recommended to start with low air pressure/flow (slowly) at the beginning. This is not necessary if the pump is filled with liquid before start.**
- When the pump has been filled with liquid, the air pressure/flow may be raised in order to increase the suction capacity of the pump.
- The performance of the pump can be adjusted through the air supply by using a needle valve and a pressure regulator. The performance can also be adjusted by normal flow control on the discharge side of the system.

2.2.1. Dry running

Although the pump is prepared for dry running it is important to have in mind that long periods of dry run may cause damage to the air valve and circlips. Also an empty pump should operate at low speeds – controlled by a needle-valve.

2.2.2. Optimization of the pump lifetime

- Running at full frequency (maximum air pressure/flow) continuously will cause premature wear of the components. When there is possibility of the pump running dry or/and at full frequency it is recommended to use an air valve with a PET piston. As a general rule, we recommend to run at half of the maximum capacity of the pump. For instance, a TX94 pump should run continuous at maximum 40 l/min.
- As stated in chapter 1.8.1. Tapflo recommends to use an appropriate air treatment system in order to extend the pump's lifetime.
- If the air humidity is high, use of a water separator or air dryer is recommended. Otherwise on the air discharge side due to decompression, icing on the muffler can appear causing it to shrink and eventually it can shoot out of its socket.
- If the ambient air is humid, icing can occur outside of the muffler. In such case it is recommended to use a longer exhaust of the compressed air (ca. 500 mm / 19,7").
- If icing / freezing is still a problem with the standard muffler, we recommend using our heavy duty metal muffler. Contact us for more information.



2. OPERATION

- When the pump is shut down while pumping a liquid containing particles, the particulate matter contained in the liquid will be deposited and get stuck inside the pump chamber. Therefore after finishing work the pump must be emptied of the remaining fluid. Otherwise, when starting the pump again, the diaphragm may get damaged and the shaft may bend leading to grub screw fracture.

2.3. Pump stopping

The pump can be stopped in two ways:

- 1) By closing of the discharge valve. The pressure from the system will stop the pump automatically. The pump restarts easily when the valve is opened again.
NOTE! When using this method keep in mind that air must be supplied to the pump. This is essential to keep the diaphragms in balance what protects them from premature failure.
- 2) By cutting off the air supply.
NOTE! When using this method make sure that the discharge valve is opened to relief the pumps pressure.

2.4. Residual risks

Even with proper application and observance of all points listed in this operating manual, there is still an estimable and unexpected residual risk when using the pumps. It may leak, fail due to wear, application-related causes or system-related circumstances.

2.5. Disposal after expiration of the expected lifetime

The metallic components like aluminium, stainless steel and carbon steel can be recycled. Plastic parts are not recyclable and must be disposed of as residual waste. The pump must be disposed of properly, according to local regulations. It should be noted that potentially dangerous fluid residues may remain in the pump and can create a hazard to the operator or the environment, therefore the pump has to thoroughly cleaned before disposal.

2.6. Actions in emergency



In case of transferred liquid leakage, the air supply have to be closed and the hydraulic pressure at pump discharge released. During spillage of an aggressive liquid, local and national safety rules must be followed.

2. OPERATION

2.7. Cleaning of the pump

2.7.1. CIP and SIP



The importance of easy cleaning is essential in hygienic applications. Tapflo aseptic pumps are designed for CIP (Cleaning In Place) and SIP (Sterilization In Place). This allows the pump to be internally cleaned without disassembly. The pump can be cleaned by flushing through with a CIP fluid (usually a mild solution of sodium hydroxide and a sanitizing additive) or by injection of hot steam (SIP). Despite the general temperature restriction (see 6.4. "Technical data"), a brief operation (max. 30 minutes) at 130°C (266°F) for sterilization process is permitted. Make sure that the CIP fluid is compatible with the materials in the pump/piping.

During CIP and SIP pump must run slowly (1-2 strokes per second) to obtain pressure balance on both sides of the diaphragm. Lack of pressure balance will have influence on the pump's lifetime. Direction of the forced flow should be, the same as during normal operation, from the inlet to the outlet. Contact us for more information.

2.7.1.1. Drainage of the pump TX94 – TX444

After the CIP procedure, the pump usually has to be drained from the CIP fluid. The Tapflo aseptic series is supplied with a hygienic stand, enabling 180° rotation of the pump unit.

- 1) Disconnect the pump from the piping.
- 2) Simply loosen the two socket head cap screws (pos. 174 – see chapter 5. "Spare parts"), rotate the pump 180° (until the pump rotation will be locked) and let the remaining fluid drain off. The airline may be left connected during this operation.
- 3) Rotate back to normal position, connect the pump with the piping and fix the socket head cap screws (pos. 174).

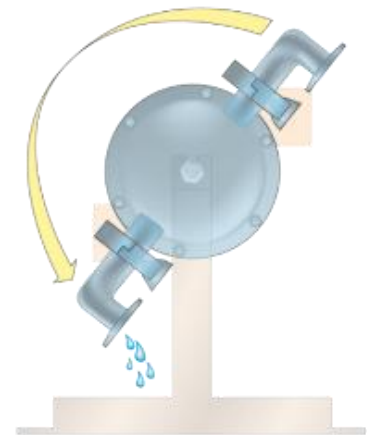

2.7.1.2. Limited possibility of draining the pump

When there's lack of possibility of rotating the pump, use special designed magnetic ball lifters. For more details please check chapter 4.1. „Magnetic ball lifter“.

3. MAINTENANCE

3. MAINTENANCE

3.1. When the pump is new or reassembled



If the pump is new or reassembled after maintenance it is important to retighten the pump housing nuts (pos. 37) after one week of operation.

Make sure to use the right torque – see chapter 6.5. "Tightening torques".

3.1.1. Performance test

When installation is new, a test run of the pump should be conducted. Gauge the capacity at specific air pressure/flow. This information is useful for checking performance in the future as wear takes place. You will be able to set schedules for maintenance of the pump and to select spare parts to be kept on stock.

3.2. Routine inspection



Frequent observation of the pump operation is recommended to detect problems. A change in sound of the running pump can be an indication of wearing parts (see chapter 3.4. "Location of faults" below).

Leaking liquid from the pump and changes of performance may also be detected. Routine inspections should be conducted frequently.

We recommend to conduct a daily check and keep records of the following:

- Leakage of fluid from any connection of the pump
- Tightness of all connection parts of the pump and any peripheral equipment
- Complete inspection in regular intervals has been done
- In case any of the above is not fulfilled, do not start the pump and implement corrective actions.
- Establish a preventive maintenance schedule based on the pump's service history.

Scheduled maintenance is especially important to prevent spills or leakage due to diaphragm failure.

3.3. Complete inspection



The intervals for a complete inspection depend upon the operation conditions of the pump. The characteristics of the liquid, temperature, materials used in the pump and running time decide how often a complete inspection is necessary.

Nevertheless, Tapflo recommends to inspect the pump at least once a year. Parts from **KIT AIR** and **KIT LIQ** should be changed during inspection. See paragraph 5.7. „Stocking recommendations“ for detailed KIT content.

If a problem has occurred, or if the pump is in need of a complete inspection, refer to chapters 3.4. "Location of faults" and 3.5 "Disassembly of the pump". You are of course warmly welcome to consult us for further help.

Parts that are subject to wear should be kept in stock, see our recommendations in chapter 5.7. „Stocking recommendations“.

3. MAINTENANCE

3.4. Location of faults

PROBLEM	POSSIBLE FAULT	POSSIBLE SOLUTION
The pump does not run	The air pressure is too low The air connection is blocked Muffler is blocked Air valve is defective Dirt in the pump chamber Diaphragm breakdown	Increase air pressure via a filter-regulator Check / clean air supply connection Check / clean / replace muffler Clean / replace complete air valve Remove debris from the chambers Replace diaphragm
The suction is bad	Suction connection is not tight Suction connection is blocked Muffler is blocked Valve balls are blocked or damaged Valve seats are worn Pump starts with high pressure Air in suction / discharge line Dry suction against discharge pressure	Tighten the suction line Clean suction line Check / clean / replace muffler Check dimensions and shape of valve balls Check dimensions and shape of valve seats Start the pump slowly (see chapter 2.2) Vent suction / discharge line Wet the pump / start without discharge pressure
The pump runs irregular	Valve balls are blocked Sealing in centre block Air valve is defective Diaphragm breakdown Valve seats are worn Icing on the muffler	Check dimensions and shape of valve balls Replace sealing Clean / replace air valve Replace diaphragm Check dimensions and shape of valve seats Improve air quality (see chapters 1.8.1 and 2.2.2)
Bad flow/pressure	Pressure fall in air supply Pressure losses on suction side Air supply / air valve leaking Suction or air connection blocked Muffler is blocked Valve ball worn or broken Valve seats are worn Air in liquid Diaphragm breakdown Icing on the muffler	Increase air pressure via a filter-regulator Check/change installation on suction side Check / repair / replace air supply / air valve Check / clean air supply / suction connection Check / clean / replace muffler Check dimensions and shape of valve balls Check dimensions and shape of valve seats Seal suction line; check / refill container Check / replace diaphragms Improve air quality (see chapters 1.8.1 and 2.2.2)
Liquid leaks from the pump	Screws on the housing not properly tightened Sealing on manifolds damaged Damaged diaphragm Tension / stress from the installation	Check tightening torques of the screws Replace sealing Check / replace diaphragms Adjust installation, eliminate stress, when using a dampener provide separate support for it (see dampener IOM manual).
Liquid comes out of the muffler	Diaphragm breakdown	Replace diaphragm
Diaphragm breakdown	Wrong selection of material Too high pressure in the installation Long periods of dry running Too high pressure on suction side	Contact us for information on material selection Use air treatment system for protection When dry, run pump slowly (see chapter 2.2) Make sure there is pressure balance between the air and liquid side of the diaphragm

3. MAINTENANCE

3.5. TX94-TX444 – Disassembly of the pump

The numbers put in brackets, refer to the part numbers in the spare part drawings and spare part lists in chapter 5 "SPARE PARTS"

3.5.1. Before the disassembly procedure



Be sure to drain all liquid from the pump. Cleanse or neutralize the pump thoroughly. Disconnect the air supply and then the suction and discharge connections.

3.5.2. Disassembly video

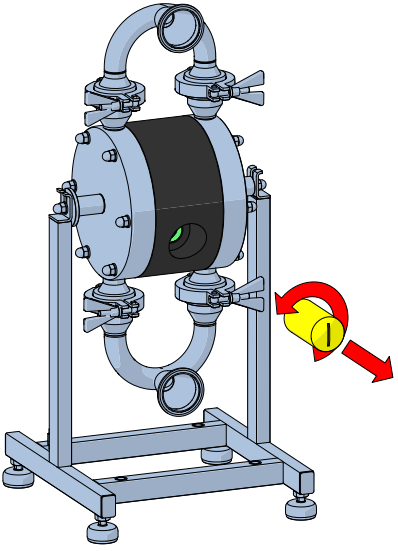
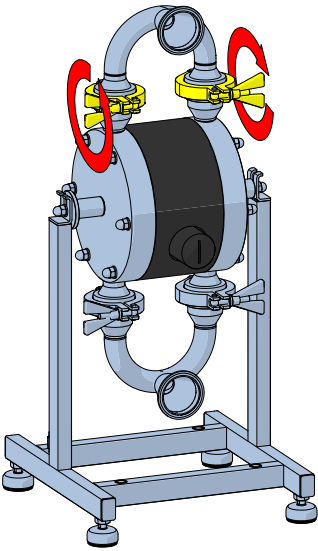

3.5.3. Disassembly procedure

	
<p>Fig. 3.5.1 Unscrew and remove muffler [25].</p>	<p>Fig. 3.5.2 Unscrew and remove 2 x tri-clamps [138] connecting the manifold [132] to the housings [11].</p>

3. MAINTENANCE

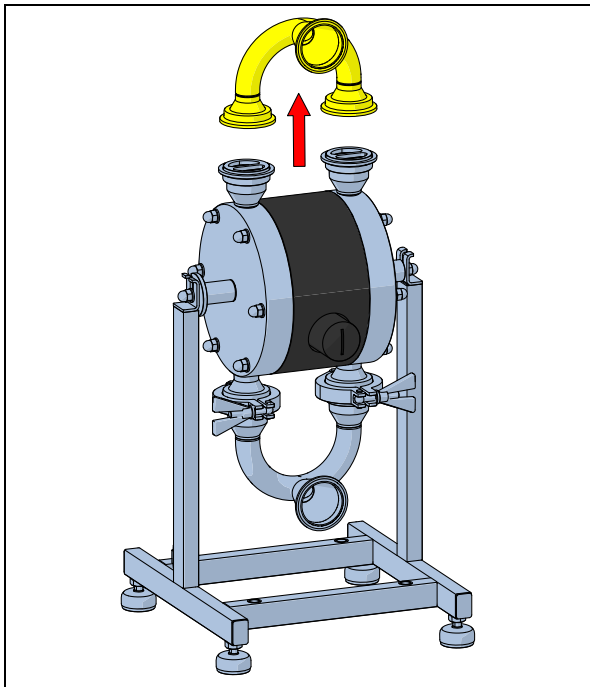

Fig. 3.5.3
Carefully take off the manifold [132].

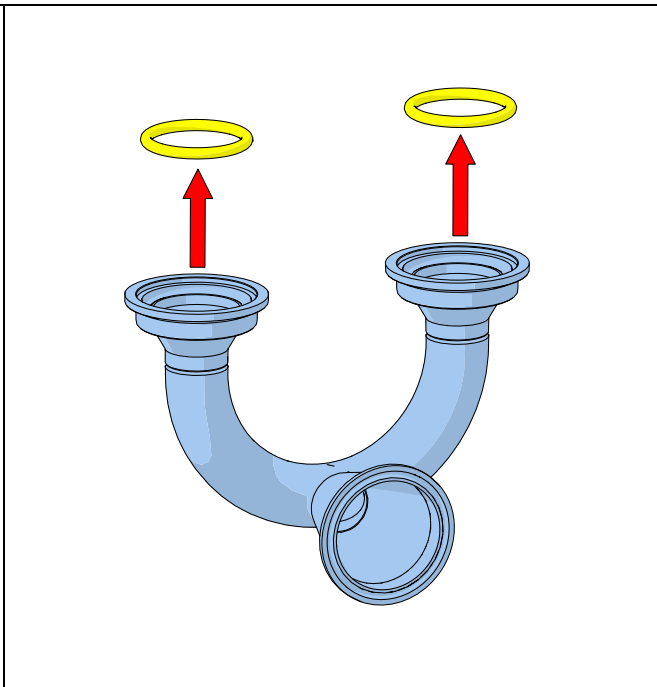

Fig. 3.5.4
Remove both sealing [18] from the manifold [132].

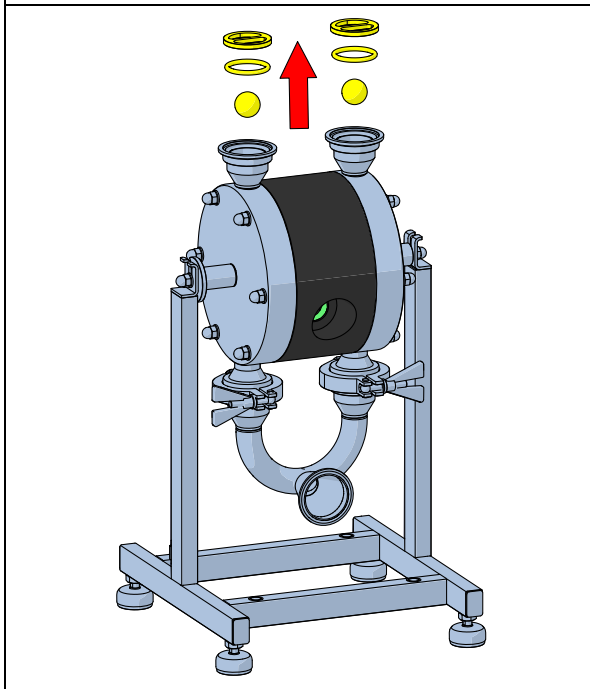

Fig. 3.5.5
Pull out 2 x valve ball stops [22], Remove the sealing [18] and valve balls [23] from the pump housing [11L] and [11P].

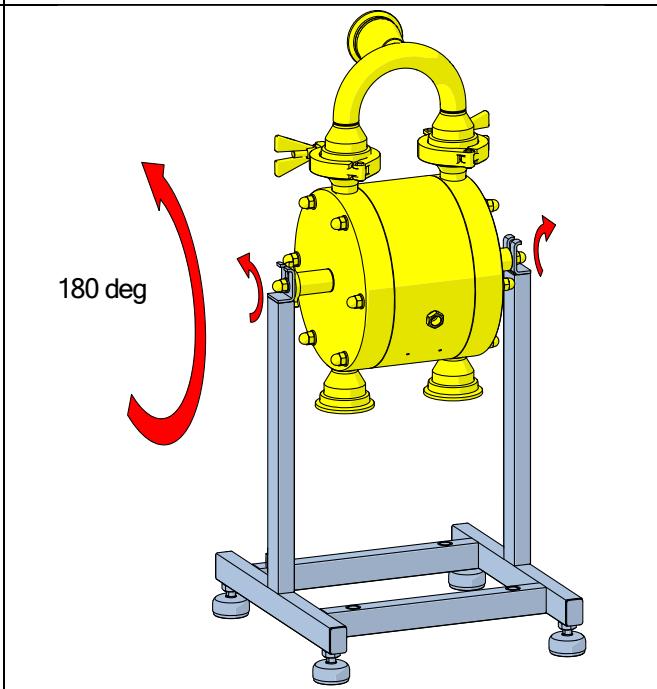
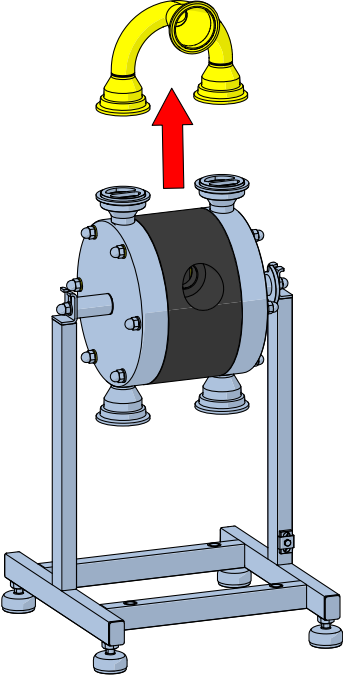
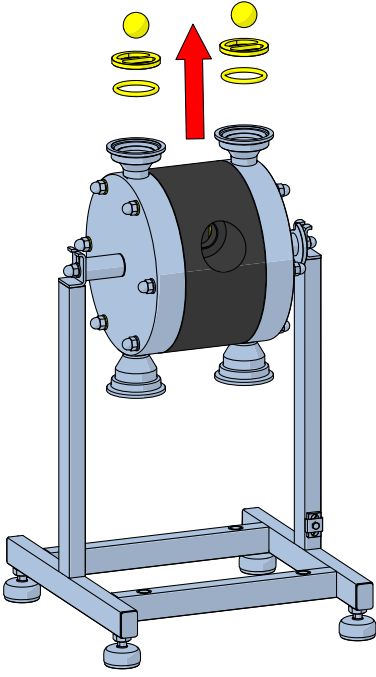
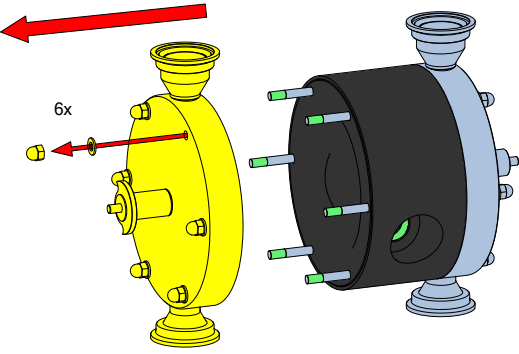
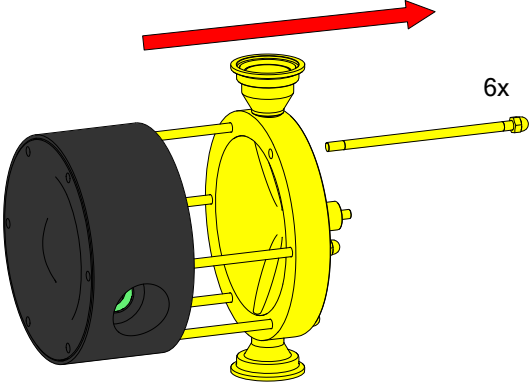
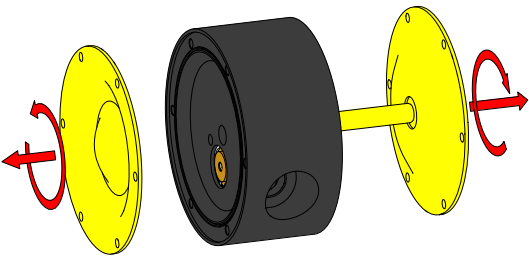

Fig. 3.5.6
Unscrew the domed nuts [174] and lift off the pump unit from the support [17]. Turn the pump upside down and tight again domed nuts [174] to ease dismantling remaining parts.

3. MAINTENANCE

	
<p>Fig. 3.5.7 Remove the lower manifold [131] from the pump housing [11L] and [11P].</p>	<p>Fig. 3.5.8 Pull out 2 x valve ball stops [22], Remove the sealing [18] and valve balls [23] from the pump housing [11L] and [11P]. Unscrew the domed nuts [174] and lift off the pump unit from the support [17].</p>
	
<p>Fig. 3.5.9 Unscrew the domed nuts [37] and washers [38] and remove it together with pump housing [11L].</p>	<p>Fig. 3.5.10 Carefully lift off the loose housing [11P] from the centerblock [12].</p>
	<p>Fig. 3.5.11 Unscrew the diaphragm [15] from one side of the pump. Take out the second diaphragm [15] along with the shaft [16].</p>

3. MAINTENANCE

a) Circlip mounted air valve – TX94

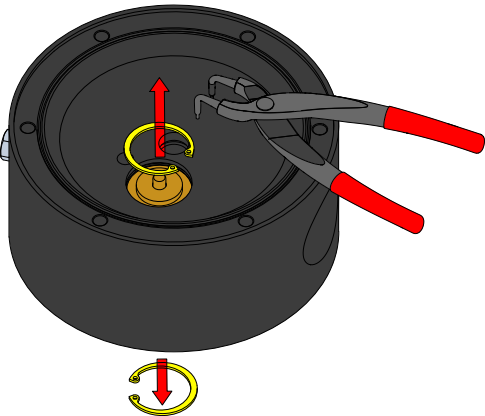
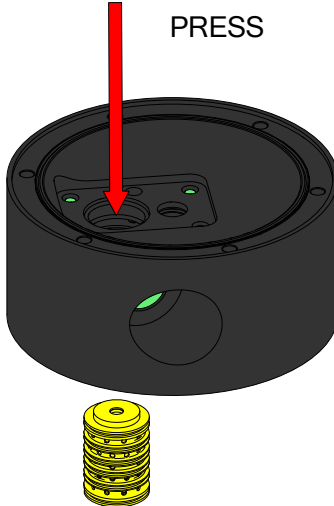
	
<p>Fig. 3.5.12 Using pliers remove both circlips [27] from the centre block [12]. Attention! While doing this, cover yourself with your other hand, as the circlip easily flips away.</p>	<p>Fig. 3.5.13 Press out the air valve [61] by means of a pressing device. Be careful not to damage the brass edges of the air valve.</p>

b) Plate mounted air valve – TX144-TX444

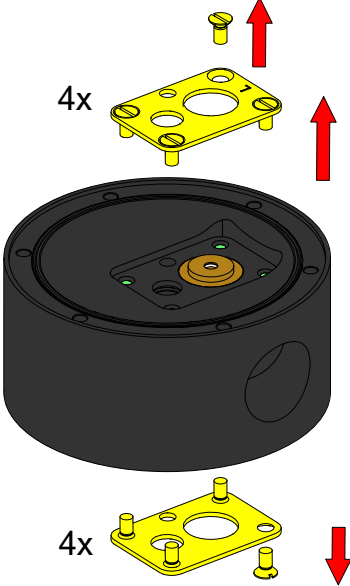
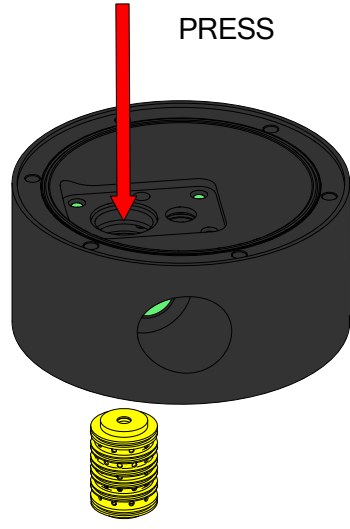
	
<p>Fig. 3.5.14 Unscrew plate screws [2711] from both sides of the centre body [122] and take out the left and right plate [271].</p>	<p>Fig. 3.5.15 Press out the air valve [61] by means of a pressing device. Be careful not to damage the brass edges of the air valve.</p>

The pump is now completely disassembled. Check all components for wear or damage and replace if necessary. When air valve is removed from the centre body check the external O-rings [30] condition and replace if necessary.

3. MAINTENANCE

3.6. TX94-TX444 – assembly of the pump

The assembly procedure is done in the reverse order to the disassembly. Nevertheless there are a few things that you have to remember in order to assemble the pump correctly.

3.6.1. Assembly video



3.6.2. Assembly procedure

<p>Fig. 3.6.1 When putting the air valve [61] into the centre block [12], apply some water or alcohol on the O-rings to provide smooth insertion of the air valve. It is recommended to use a pressing device for this operation.</p>	<p>Fig. 3.6.2 When there is need to replace the diaphragm pin screw [1652], while screwing it into the diaphragm [15] make sure it is done with the appropriate torque, referring to values in the table below:</p> <table border="1" data-bbox="826 1440 1153 1646"> <thead> <tr> <th>PUMP SIZE</th> <th>TORQUE [Nm]</th> </tr> </thead> <tbody> <tr> <td>TX94</td> <td>10</td> </tr> <tr> <td>TX144</td> <td>13</td> </tr> <tr> <td>TX244</td> <td>20</td> </tr> <tr> <td>TX444</td> <td>22</td> </tr> </tbody> </table>	PUMP SIZE	TORQUE [Nm]	TX94	10	TX144	13	TX244	20	TX444	22
PUMP SIZE	TORQUE [Nm]										
TX94	10										
TX144	13										
TX244	20										
TX444	22										

3. MAINTENANCE

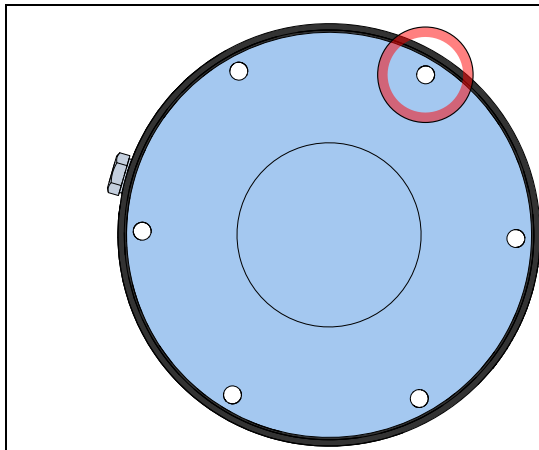

Fig. 3.6.3

When screwing in the diaphragms [15] on the shaft [16], the holes in the diaphragms must align with the holes in the centre block [12]. Sometimes it is necessary to turn the diaphragm back a little bit in order to align the holes.

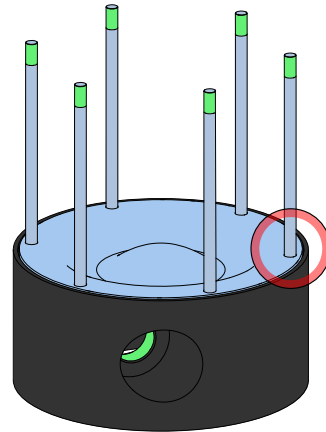

Fig. 3.8.4

When putting in the pin screws [14] take extra care not to damage the diaphragms [15] with the pin screw thread.

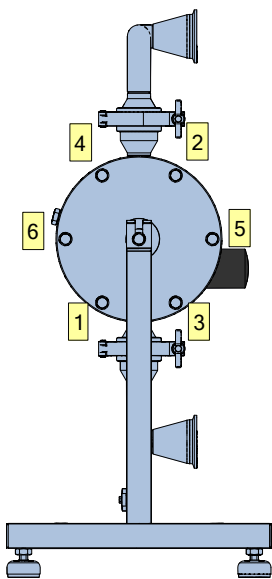

Fig. 3.6.4

When fastening the domed nuts, remember to do it according to the tightening procedure and with the appropriate torque (see 6.5 "Tightening torques").

NOTE! After a few weeks of operation retighten the domed nuts with the appropriate torque.

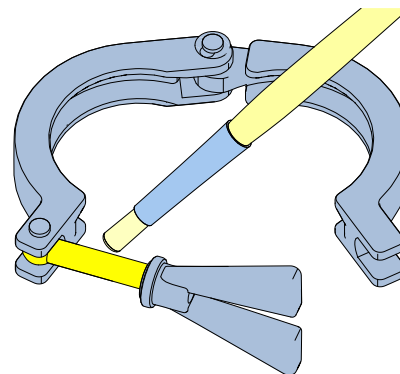

Fig. 3.6.5

When fastening the tri-clamps apply some FDA grade lubricate on the thread.

3.6.3. Test run



We recommend you to conduct a test run of the pump before installing it in the system, so no liquid gets wasted if the pump leaks or perhaps does not start accordingly to wrong assembly of the pump.

After one week of operation retighten the nuts with appropriate torque.

4. OPTIONS

4. OPTIONS

4.1. Magnetic ball lifters

New magnetic ball lifters have been implemented in pump sizes TX94 – TX244. They are implemented to enable pump emptying when no other draining option is available. Rotating the pump is no longer needed.

The balls are lifted by simply attaching the magnets to the pumps manifold.

Valve balls are available in AISI 420 magnetic stainless steel or PTFE with steel core.



Additional / different parts:

Art. no	Q-ty	Description
6-xxx-23-15	4	Valve ball – PTFE/steel core
6-xxx-23-59	4	Valve ball - AISI420
6-xxx-95M	4	Magnetic ball lifter
6-xxx-170	1	Magnet holder

Pump emptying procedure:

- Install the magnets on the pump manifolds in the area of the valve seat.
- Run the pump slowly.
- After a few cycles the pump will start to run dry.
- Turn off the pump.
- Take off the magnets off the manifolds.

CIP and SIP cleaning procedure recommendation:

During cleaning procedures do not use magnetic ball lifters. When the ball is pulled by the lifter and facing the manifold wall it may trap some liquid to stay inside.

NOTE! Remember to run the pump slowly during cleaning procedures to ensure the diaphragms are balanced on air and liquid side.

NOTE!



The ball lifting system is built with high intensity NdFeB magnets therefore all pacemaker carriers must not approach the ball lifting system components! Intense magnetic field can disturb heart pace. What is more, all devices that can be damaged due to intense magnetic field must not be placed in the vicinity of the ball lifters.



It is important not to join the magnets as it might be difficult to separate them from each other. Furthermore, the magnets are fragile and when connected can crumble.

5. SPARE PARTS

5. SPARE PARTS

5.1. TX94 – Spare parts drawing

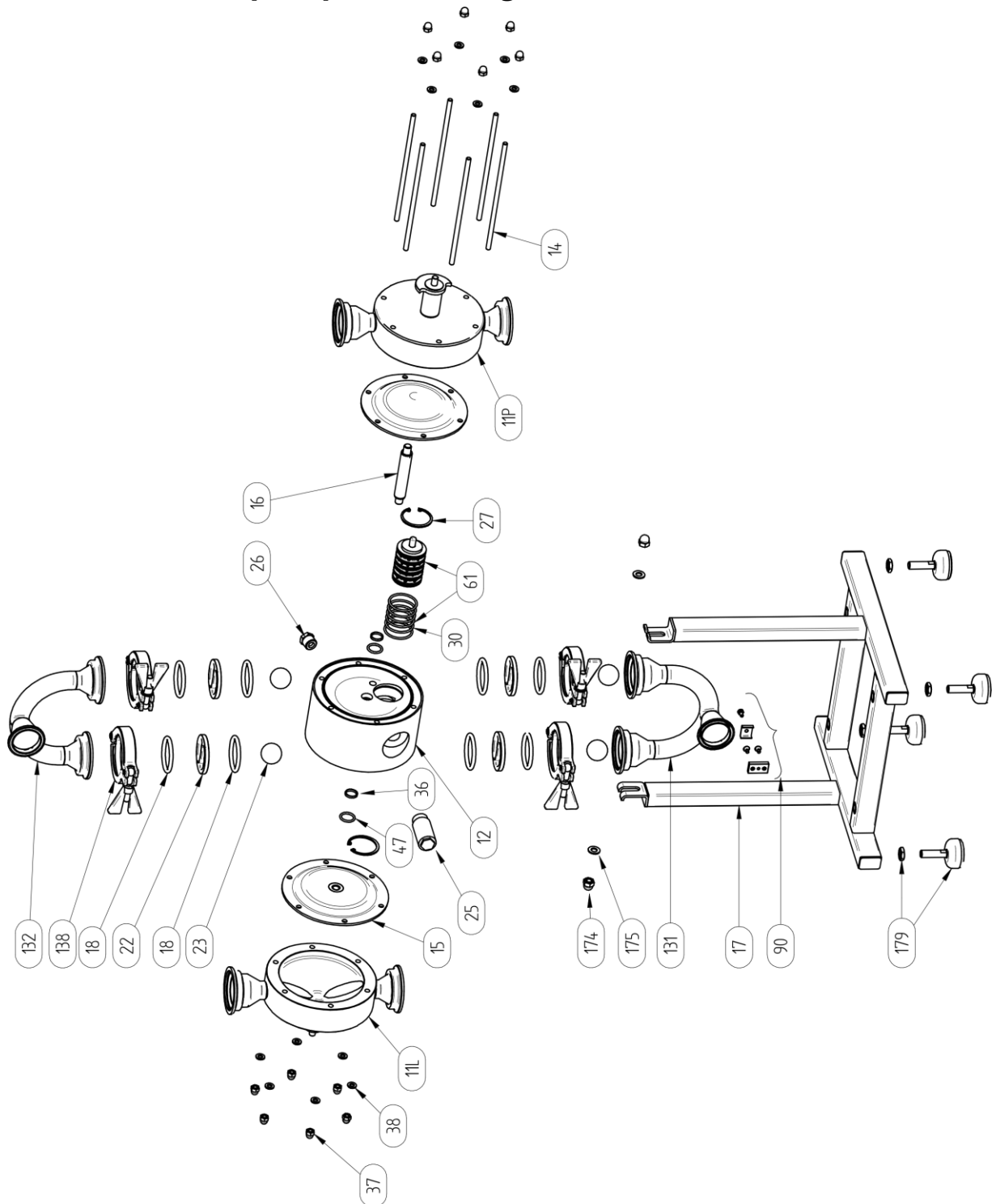

5. SPARE PARTS

5.2. TX94 – Spare parts list

Pos.	Q-ty	Description	Material	KIT LIQ	KIT AIR
11L	1	Housing left side	AISI 316L		
11R	1	Housing right side	AISI 316L		
12	1	Centre block	PP, Conductive PP		
131	1	Manifold inlet	AISI 316L		
132	1	Manifold outlet	AISI 316L		
138	4	Tri-clamp	AISI 304L		
14	6	Pin screw	A4-80		
15	2	Diaphragm	PTFE / EPDM (standard), PTFE TFM1705B / EPDM, PTFE / white EPDM	X	
16	1	Diaphragm shaft	AISI 304L		
17	1	Stand	AISI 304L		
174	2	Domed nut	A4-70		
175	2	Washer	A4-70		
179	4	Adjustable foot set	AISI 316L		
18	8	O-ring	EPDM (standard), FKM, FEP/FKM	X	X
22	4	Valve ball stop	AISI 316L		
23	4	Valve ball	Modified PTFE (standard), AISI 316L	X	
25	1	Muffler	PP		X
26	1	Air intake adapter	Brass		
27	2	Circlip	Cr3 coated steel		
30	6	O-ring	NBR, FKM, EPDM		
36	2	Centre block seal	PE		X
37	12	Domed nut	A4-70		
38	12	Washer	A4-70		
47	2	O-ring(back up for 36)	NBR		X
61	1	Air valve complete	Brass/NBR (standard), AISI 316L/FKM, Brass/EPDM, AISI 316L/FKM, PET/FKM		X
90	1	Earthing (complete)	AISI 316L		

5. SPARE PARTS

5.3. TX94 – Spare parts options

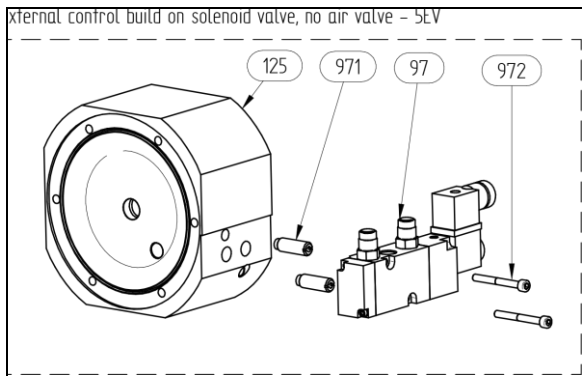

External control – built on solenoid valve			
125	1	Center block	PP, PP Cond.
97	1	Solenoid valve	-
971	2	Threaded insert	AISI 316L
972	2	Screw	A4-70

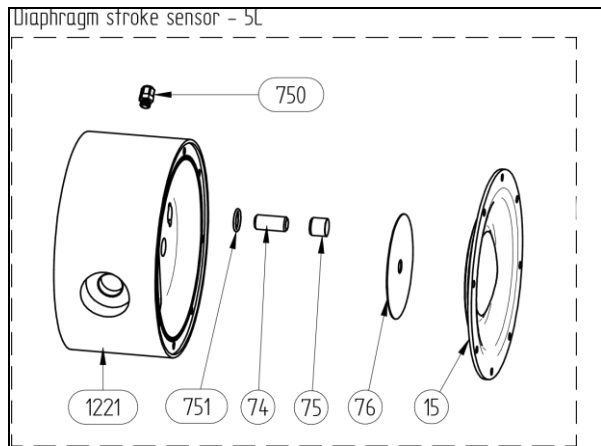

Diaphragm stroke sensor			
1221	1	Centerblock for stroke sensor	PP
751	1	O-ring	NBR, FKM, EPDM
74	1	Inductive sensor	CuZn
75	1	Sensor cap	PP
76	1	Sensing plate	AISI 316L
750	1	Cable gland	PP

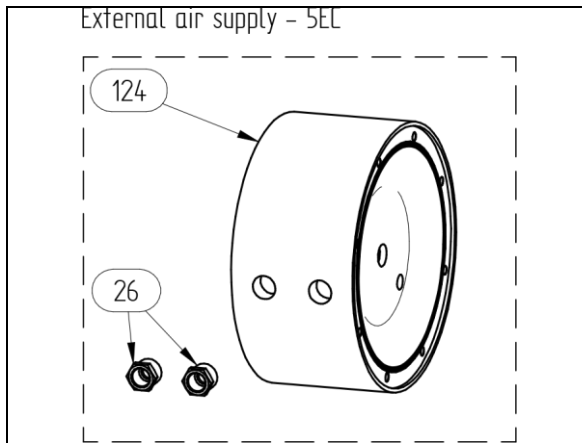

External air supply			
124	1	Center block	PP, PP Cond.
26	2	Air intake adapter	Brass

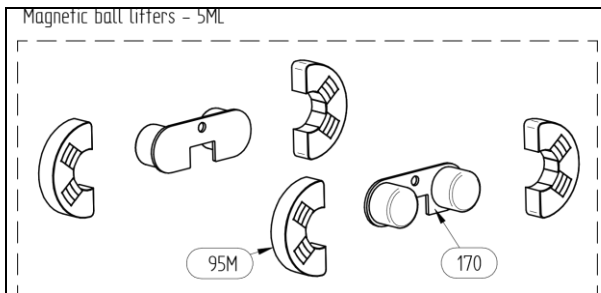

Magnetic ball lifters			
23-15	4	Valve ball	PTFE/SS core
23-59	4	Valve ball	AISI420
95M	4	Magnetic ball lifter	PE1000
170	2	Holder	AISI316L

5. SPARE PARTS

5.4. TX144-TX444 – Spare parts drawing

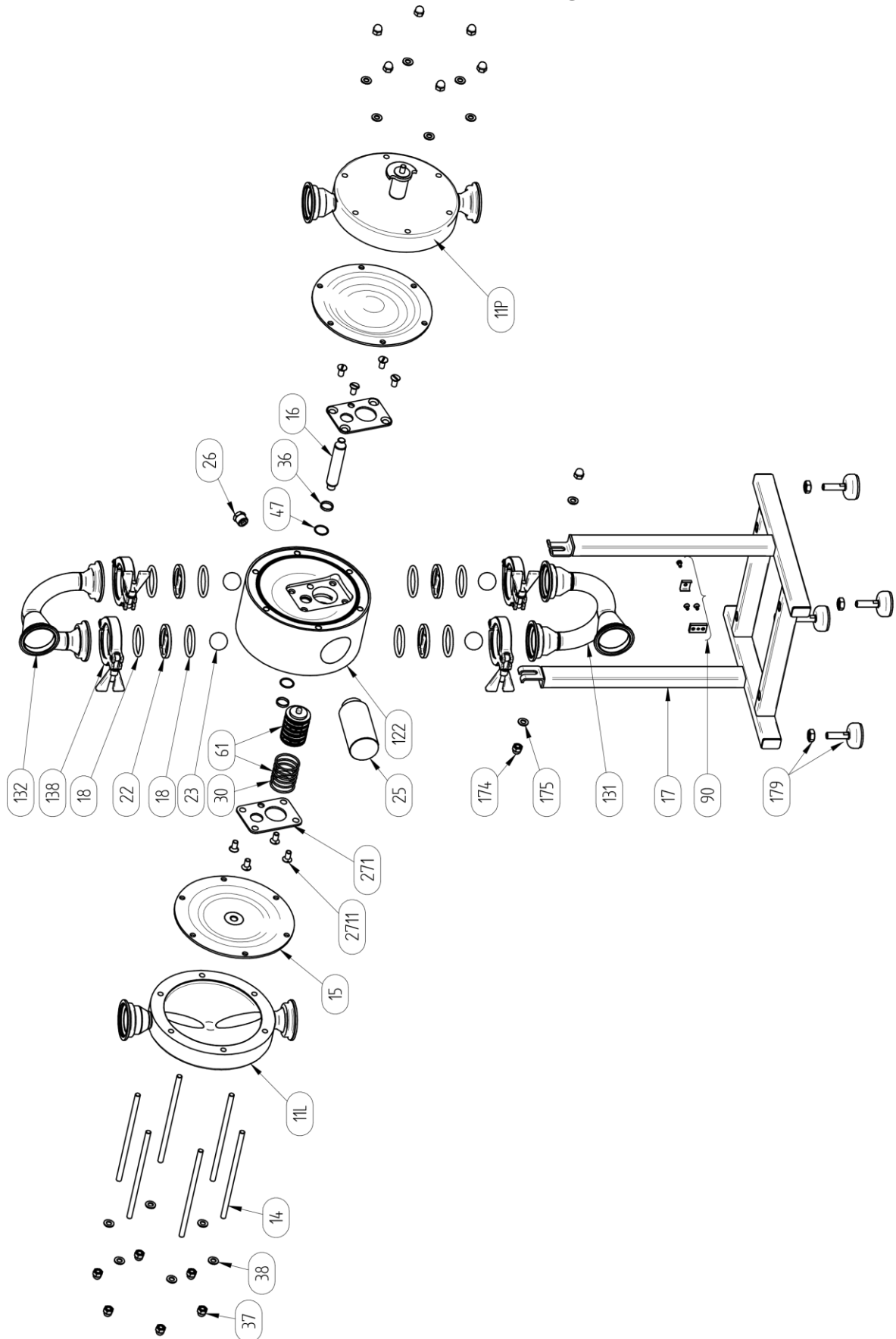

5. SPARE PARTS

5.5. TX144-TX444 – Spare parts list

Pos.	Q-ty	Description	Material	KIT LIQ	KIT AIR
11L	1	Housing left side	AISI 316L		
11R	1	Housing right side	AISI 316L		
122	1	Centre block	PP, Conductive PP		
131	1	Manifold inlet	AISI 316L		
132	1	Manifold outlet	AISI 316L		
138	4	Tri-clamp	AISI 304L		
14	6/8*	Pin screw	A4-80		
15	2	Diaphragm	PTFE / EPDM (standard), PTFE TFM1705B / EPDM, PTFE / white EPDM	X	
16	1	Diaphragm shaft	AISI 304L		
17	1	Stand	AISI 304L		
174	2	Domed nut	A4-70		
175	2	Washer	A4-70		
179	4	Adjustable foot set	AISI 316L		
18	8	O-ring	EPDM (standard), FKM, FEP/FKM	X	X
22	4	Valve ball stop	AISI 316L		
23	4	Valve ball	Modified PTFE (standard), AISI 316L	X	
25	1	Muffler	PP		X
26	1	Air intake adapter	Brass		
271	1	Set 2 plates (left and right)	AISI 316L		
2711	8	Screw	A4-70		
30	6	O-ring	NBR, FKM, EPDM		
36	2	Centre block seal	PE		X
37	12/16**	Domed nut	AISI 316L		
38	12/16**	Washer	AISI 316L		
47	2/4***	O-ring(back up for 36)	NBR		X
61	1	Air valve complete	Brass/NBR (standard), AISI 316L/FKM, Brass/EPDM, AISI 316L/FKM, PET/FKM		X
90	1	Earthing (complete)	AISI 316L		

* 6 for TX144 / 8 for TX244 and TX444

** 12 for TX144 / 16 for TX244 and TX444

*** 4 for TX144 / 2 for TX244 and TX444

5. SPARE PARTS

5.6. TX144 – TX444 – Spare parts options

External control on solenoid valve, no air valve - 5EV

External control – built on solenoid valve			
125	1	Center block	PP, PP Cond.
97	1	Solenoid valve	-
971	2	Threaded insert	AISI 316L
972	2	Screw	A4-70

Diaphragm stroke sensor - 5L

Diaphragm stroke sensor			
1221	1	Centerblock for stroke sensor	PP
751	1	O-ring	NBR, FKM, EPDM
74	1	Inductive sensor	CuZn
75	1	Sensor cap	PP
76	1	Sensing plate	AISI 316L
750	1	Cable gland	PP

External air supply - 5EL

External air supply			
124	1	Center block	PP, PP Cond.
26	2	Air intake adapter	Brass

Magnetic ball lifters - 5ML

Magnetic ball lifters			
23-15	4	Valve ball	PTFE/SS core
23-59	4	Valve ball	AISI420
95M	4	Magnetic ball lifter	PE1000
170	2	Holder	AISI316L

5. SPARE PARTS

5.7. Stocking recommendation

Even at normal operation some details in the pump will be worn. In order to avoid expensive breakdowns we recommend having a few spare parts in stock.

Depending on the severity of the operation and the importance of assuring continuous work we offer two different spare part **KITS** – **KIT LIQ** includes parts on pump wetted side and **KIT AIR** includes parts on the pump air side that are subject to wear.

TX94, TX144, TX244, TX444:

	Pos.	Description	Q-ty
KIT LIQ	15	Diaphragm	2
	18	Sealing	8
	23	Valve ball	4

TX94, TX144, TX244, TX444:

	Pos.	Description	Q-ty
KIT AIR	18	O-ring/gasket set	8
	61	Air valve complete	1
	16	Diaphragm shaft	1
	36	Centre block seal	2
	47	O-ring(back up for 36)	2/4*
	25	Muffler	1

* 4 for TX144 / 2 for TX94, TX244 and TX444

5.8. How to order parts

When ordering spare parts for Tapflo pumps, please let us know what is the **model number** and **serial number** from the pump centerblock. Then just indicate the part numbers from the spare parts list and quantity of each item.

5. SPARE PARTS

5.9. Pump code

The model number on the pump and on the front page of this instruction manual tells the pump size and materials of the pump.

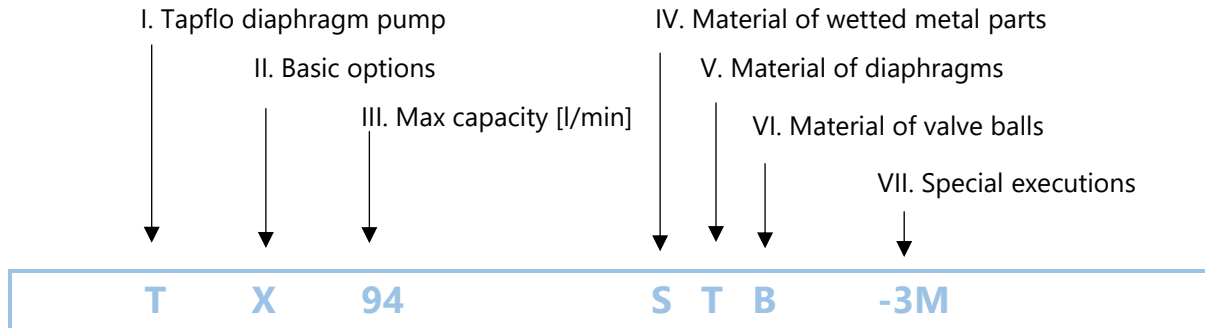

I. T = Tapflo diaphragm pump

II. Basic options:

B = Backup diaphragm pump

X = ATEX approved, group II, cat. 2

IV. Material of wetted metal parts:

S = stainless steel AISI 316L – 1.4404 (standard)

F = stainless steel AISI 316L – 1.4435 (optional)

IV. Material of diaphragms:

T = PTFE TFM / EPDM back

B = PTFE TFM 1705B / EPDM back

Z = PTFE / white EPDM back

Material of valve balls:

B = Modified PTFE

S = AISI 316 stainless steel

V. Special executions:

3 = Optional connection type

4 = Backup diaphragm system configuration

5 = Other special executions*

6 = Optional material of centre body

7 = Optional material of air valve

8 = Optional material of pos. 18 seals

9 = Optional material of housing pin screws

* Ask us for complete pump code with all available options and executions

6. DATA

6. DATA

6.1. Capacity curves

The performance curves are based on water at 20°C. Other circumstances might change the performance. See below how the capacity will change at different viscosities and suction lifts.

Example:

A flow of 30 litre/minute is desired. The discharge pressure is calculated to 25 mWC. We choose a TX94 pump. It requires an air pressure of 4 bar and will consume approximately 0.20 Nm³ of air per minute.

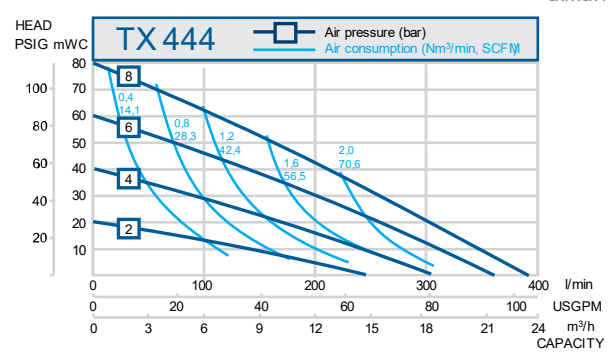
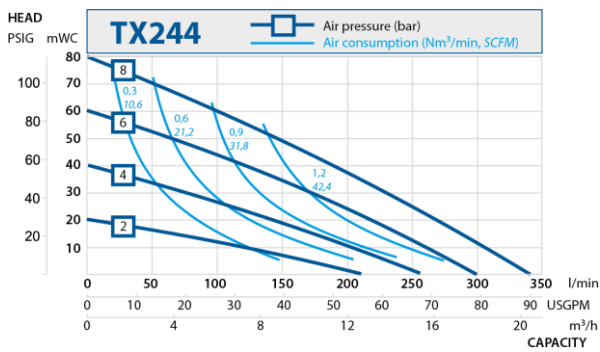
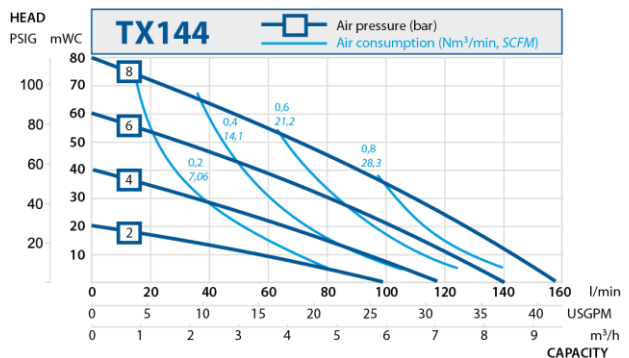
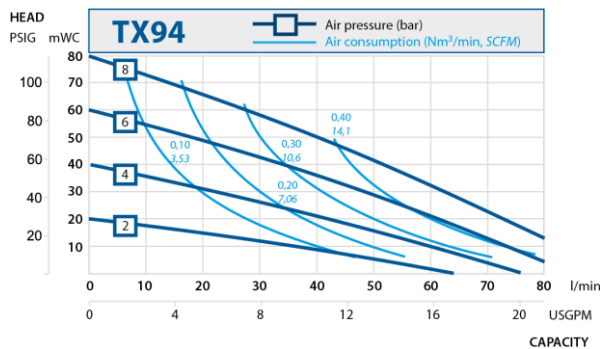

Recommended flow is half of the max flow, e.g. recommended flow for a TX94 is 40 l/min.

6.2. Capacity changes

Capacity changes at different suction lifts

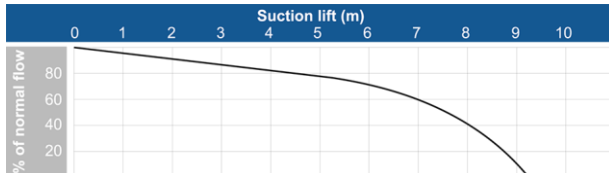

Capacity changes at different viscosities

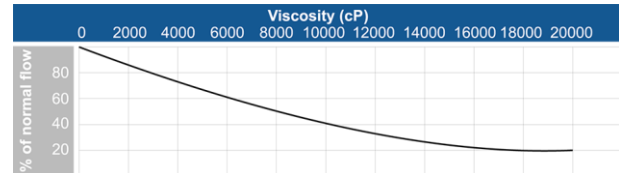

6. DATA

6.3. Dimensions

Dimensions in mm (where other is not indicated)

Dimensions in inch (where other is not indicated)

General dimensions only, ask us for detailed drawings. Changes reserved without notice.

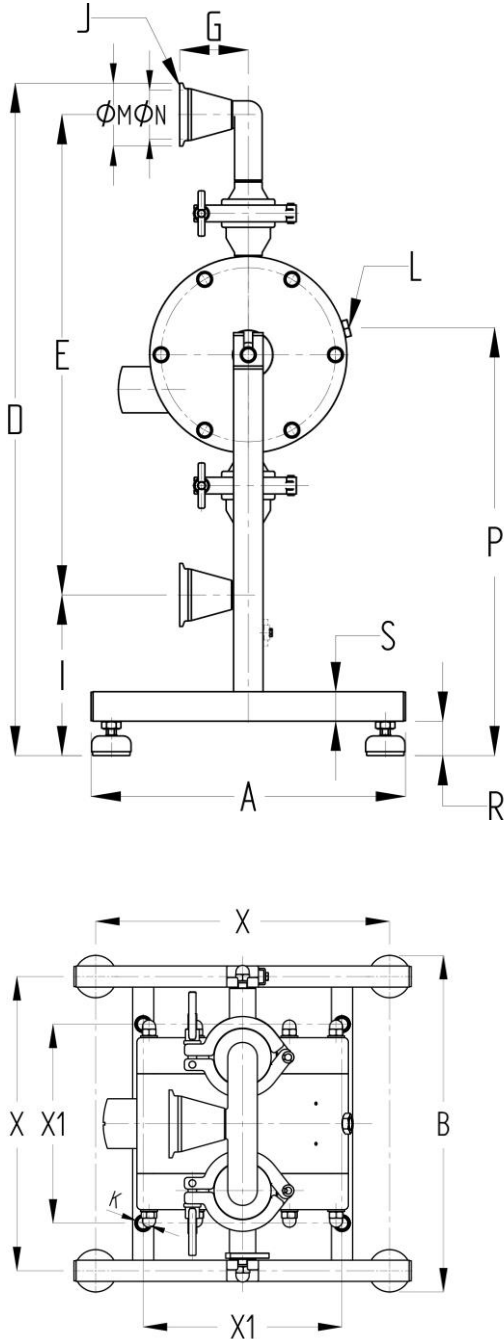

Dimension	PUMP SIZE			
	TX94	TX144	TX244	TX444
A	319	319	404	465
	12.6	12.6	15.9	18.3
B	318	318	400	473
	12.5	12.5	15.8	18.6
D	598	684	895	1091
	23.5	26.9	35.2	43.0
E	457	488	700	885
	18	19.2	27.6	34.8
G	52	70	96	114
	2.1	2.8	3.8	4.5
I	116	163	149	153
	4.6	6.4	5.9	6.0
J				
DIN32676*	DN40	DN50	DN65	DN80
K	11	11	11	11
	0.4	0.4	0.4	0.4
L	G ¼	G ¼	G ½	G ½
M	50	64	91	106
	2.0	2.5	3.6	4.2
N	38	50	66	81
	1.5	2.0	2.6	3.2
P	356	435	500	595
	14	17.1	19.7	23.4
R	35	35	35	35
	1.4	1.4	1.4	1.4
S	20	20	20	40
	0.8	0.8	0.8	1.6
X	278	278	360	433
	10.9	10.9	14.2	17.0
X1	188	188	270	331
	7.4	7.4	10.6	13.0

*Standard connection

6. DATA

6.4. Technical data

TECHNICAL DATA	PUMP SIZE			
	TX94	TX144	TX244	TX444
Max capacity [l/min] / [US GPM]	94 / 25	144 / 38	270 / 71	360 / 95
Volume per stroke* [ml] / [cu in]	95 / 19.5	256 / 31.4	796 / 86.4	1922 / 140.3
Max discharge pressure [bar] / [psi]	8 / 116	8 / 116	8 / 116	8 / 116
Max air pressure [bar] / [psi]	8 / 116	8 / 116	8 / 116	8 / 116
Max suction lift dry** [m] / [Ft]	2 / 6.6	3 / 9.8	4.4 / 14.4	5 / 16
Max suction lift wet [m] / [Ft]	8 / 26.2	9 / 29.5	9 / 29.5	9 / 29.5
Max size of solids ø in [mm] / [in]	6 / 0.24	6 / 0.24	10 / 0.39	15 / 0.6
Max temp. with EPDM [°C] / [°F]	90 / 176	90 / 176	90 / 176	90 / 176
Max temp. with PTFE [°C] / [°F]	110 / 230	110 / 230	110 / 230	110 / 230
Weight [kg] / [lb]	15 / 33	22 / 48.5	50 / 110	107 / 236

* = Based on pumps with EPDM diaphragms. Pumps with PTFE diaphragms have about 15% less volume.

** = With stainless steel valve balls, other materials may reduce suction. Please consult us in this matter.

COMPONENT	MATERIAL
Wetted metal details	AISI 316L, Ra 0.8 Ra 0.5 on request
Centre block (not wetted)	PP conductive
Diaphragms (wetted/not wetted)	PTFE (FDA & USP VI) / EPDM back PTFE 1705B (FDA & USP VI) / EPDM back PTFE (FDA & USP VI) / white EPDM back
Valve balls (wetted)	PTFE (FDA & USP VI) Modified PTFE (FDA & USP VI) AISI 316L
Air valve (not wetted)	Brass (std.), stainless steel AISI 316L or PET with NBR (std.), EPDM or FKM O-rings
Sealing (wetted)	EPDM (FDA & USP VI) FKM (FDA & USP VI) FEP/FKM (FDA & USP VI)
Housing pin screws (not wetted)	Stainless steel A4-70
Diaphragm shaft (not wetted)	Stainless steel AISI 304L

6.5. Tightening torques

Checking of the tightening torques is necessary after all periods of stoppage, when temperature variations are a factor and after all transport and maintenance of the pump. What is more for proper operation and safety the torque values should be checked frequently as part of preventive maintenance (please contact Tapflo for interval proposals). Although pump applications vary, a general guideline is to re-torque the pump every two weeks.

PUMP SIZE	MOUNTING TORQUE [Nm]
TX94	8
TX144	16
TX244	20
TX444	23

6. DATA

6.6. Permitted loads on manifolds

We recommend not to exceed the following loads and forces reacting on the manifolds.

TX94		
Direction	Load [N] (inlet/outlet)	Moment of force (inlet/outlet) [Nm]
X	31	6.3
Y	31	6.3
Z	31	6.3

TX144		
Direction	Load [N] (inlet/outlet)	Moment of force (inlet/outlet) [Nm]
X	35	7.3
Y	35	7.3
Z	35	7.3

TX244		
Direction	Load [N] (inlet/outlet)	Moment of force (inlet/outlet) [Nm]
X	43	8.8
Y	43	8.8
Z	43	8.8

TX444		
Direction	Load [N] (inlet/outlet)	Moment of force (inlet/outlet) [Nm]
X	56	11.5
Y	56	11.5
Z	56	11.5

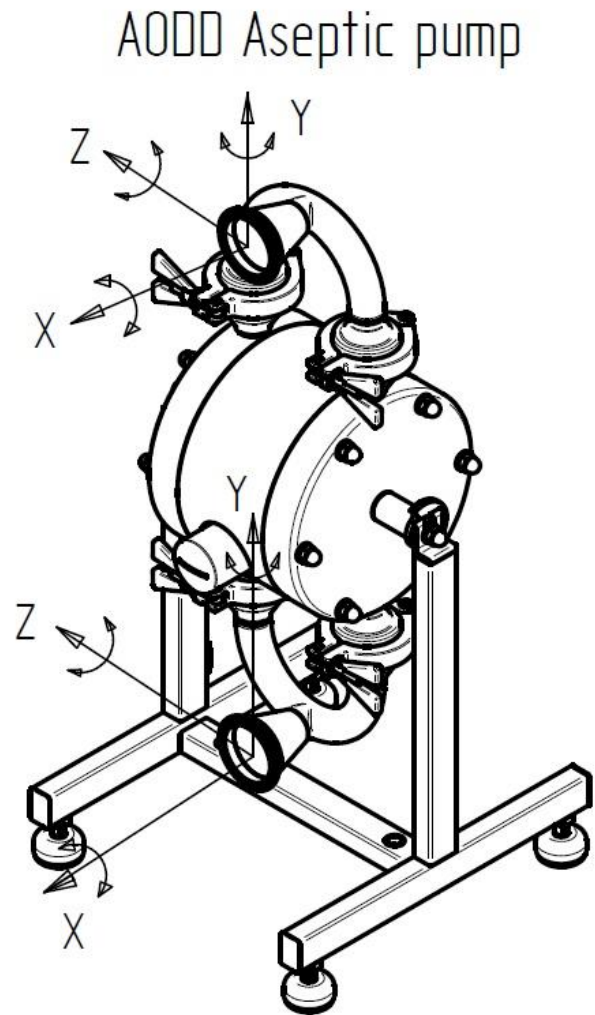

7. WARRANTY

7. WARRANTY

7.1. Warranty form

Company: _____	
Telephone: _____	Fax: _____
Address: _____	
Country: _____	Contact Name: _____
E-mail: _____	
Delivery Date: _____	Date of pump installation: _____
Pump type: _____	
Serial No (see name plate or stamped on pump housing): _____	
Description of the fault: _____	

The installation:	
Liquid: _____	
Temperature [°C]: _____	Viscosity [cPs]: _____ Spec grav. [kg/m ³]: _____ pH-value: _____
Content of particles: _____	% of max size [mm]: _____
Flow [l/min]: _____	Duty [h/day]: _____ No of starts per day: _____
Discharge head [mWC]: _____	Suction head / lift [m]: _____
Air pressure [bar]: _____	Quality of the air (filter, micron, lubrication): _____
Other: _____	

Place for sketch of installation:	

7. WARRANTY

7.2. Returning parts

When returning parts to Tapflo please follow this procedure:

- Consult Tapflo for shipping instructions.
- Cleanse or neutralize and rinse the part/pump. Make sure the part/pump is completely empty from liquid.
- Pack the return articles carefully to prevent any damage during transportation.

Goods will not be accepted unless the above procedure has been complied with.

7.3. Warranty

Tapflo warrants products under conditions as stated below for a period of not more than 5 years from installation and not more than 6 years from date of manufacturing.

1. The following terms and conditions apply to the sale of machinery, components and related services and products, of Tapflo (hereinafter "the products").
2. Tapflo (the manufacturer) warrants that:
 - a. its products are free of defects in material, design and workmanship at the time of original purchase;
 - b. its products will function in accordance with Tapflo operative manuals; Tapflo does not guarantee that the product will meet the precise needs of the Customer, except for those purposes set out in any invitation to render documents or other documents specifically made available to Tapflo before entering into this agreement;
 - c. high quality materials are used in the construction of the pumps and that machining and assembly are carried out to the highest standards.

Except as expressly stated above, Tapflo makes no warranties, express or implied, concerning the products, including all warranties of fitness for a particular purpose.

3. This warranty shall not be applicable in circumstances other than defects in material, design, and workmanship. In particular warranty shall not cover the following:
 - a. Periodic checks, maintenance, repair and replacement of parts due to normal wear and tear (seals, O-rings, rubber items, diaphragms, air valves etc.);
 - b. Damage to the product resulting from:
 - b.1. Tampering with, abuse or misuse, including but not limited to failure to use the product for its normal purposes as stated at the time of purchase or in accordance with Tapflo instructions for use and maintenance of the product, or the installation or improper ventilation or use of the product in a manner inconsistent with the technical or safety standard in force;
 - b.2. Repairs performed by non-skilled personnel or use of non-original Tapflo parts;
 - b.3. Accidents or any cause beyond the control of Tapflo, including but not limited to lightning, water, fire, earthquake, and public disturbances, etc.;

7. WARRANTY

4. The warrantee shall cover the replacement or repairing of any parts, which is documented faulty due to construction or assembling, with new or repaired parts free of charges delivered by Tapflo. Parts subjected to normal tear and wear shall not be covered by the warranty. Tapflo shall decide as to whether the defective or faulty part shall be replaced or repaired.
5. The warrantee of the products shall be valid for a period in accordance to the current law from the date of delivery, under the condition that notice of the alleged defect to the products or parts thereof be given to Tapflo in written within the mandatory term of 8 days from the discovery. Repair or replacement under the terms of this warranty shall not give a right to an extension to, or a new commencement of, the period of warranty.
6. Repair or replacement under the terms of this warranty shall not give a right to an extension to, or a new commencement of, the period of warranty. Repair or replacement under the terms of this warranty may be fulfilled with functionally equivalent reconditioned units. Tapflo qualified personnel shall be solely entitled to carry out repair or replacement of faulty parts after careful examination of the pump. Replaced faulty parts or components will become the property of Tapflo.
7. The products are built in accordance with standard CE normative and are tested (where applicable) by Tapflo. Approval and tests by other control authority are for the customer's account. The products shall not be considered defective in materials, design or workmanship if they need to be adapted, changed or adjusted to conform to national or local technical or safety standards in force in any country other than that for which the unit was originally designed and manufactured. This warranty shall not reimburse such adaptations, changes or adjustments, or attempt to do so, whether properly performed or not, nor any damage resulting from them, nor any adaptation, change or adjustments to upgrade the products from their normal purpose as described in the products operative manual without the prior written consent of Tapflo.
8. Installation, including electric and other connections to utility mains according to Tapflo drawings, is for the cost and responsibility of the customer, unless otherwise agreed in writing.
9. Tapflo will not be liable on any claim, whether in contract, tort, or otherwise, for any indirect, special, incidental, or consequential damages, caused to the customer or to third parties, including loss of profits, arising by any possible infringement of par. 3 above or by the customer or third parties being in the impossibility of using the products.

Steady the above, Tapflo liability to the customer or third parties from any claim, whether in contract, tort, or otherwise, shall be limited to the total amount paid by the customer for the product that caused the damages.

Sweden

Filaregatan 4 | S-442 34 Kungälv

Tel: +46 303 63390

Fax: +46 303 19916

E-mail addresses:

Commercial questions: sales@tapflo.com

Orders: order@tapflo.com

Tech support: support@tapflo.com

Tapflo products and services are available in 75 countries on 6 continents.

Tapflo is represented worldwide by own Tapflo Group Companies and carefully selected distributors assuring highest Tapflo service quality for our customers' convenience.

AUSTRALIA | AUSTRIA | AZERBAIJAN | BAHRAIN | BELARUS | BELGIUM | BOSNIA & HERZEGOVINA | BRAZIL | BULGARIA | CANADA | CHILE | CHINA | COLOMBIA | CROATIA | CZECH REPUBLIC | DENMARK | ECUADOR | EGYPT | ESTONIA | FINLAND | FRANCE | GEORGIA | GERMANY | GREECE | HONG-KONG | HUNGARY | ICELAND | INDIA | INDONESIA | IRAN | IRELAND | ISRAEL | ITALY | JAPAN | JORDAN | KAZAKHSTAN | KUWAIT | LATVIA | LIBYA | LITHUANIA | MACEDONIA | MALAYSIA | MEXICO | MONTENEGRO | MOROCCO | NETHERLANDS | NEW ZEALAND | NORWAY | POLAND | PORTUGAL | PHILIPPINES | QATAR | ROMANIA | RUSSIA | SAUDI ARABIA | SERBIA | SINGAPORE | SLOVAKIA | SLOVENIA | SOUTH AFRICA | SOUTH KOREA | SPAIN | SUDAN | SWEDEN | SWITZERLAND | SYRIA | TAIWAN | THAILAND | TURKEY | UKRAINE | UNITED ARAB EMIRATES | UNITED KINGDOM | USA | UZBEKISTAN | VIETNAM

Tapflo Group Companies

Australia

Tapflo Oceania (Pty) Ltd
Tel: +61 1800 303 633
sales@tapflo.com.au

Austria

Tapflo Austria
Tel: +43 732 27292910
sales@tapflo.at

Baltic States

Tapflo Latvia
Tel: +371 67472205
sales@tapflo.lv

Belarus

Tapflo Belarus
Tel: +375 17 3934609
sales@tapflo.by

Belgium

Tapflo Benelux B.V.
Tel: +31 (0)85 00 743 00
info@tapflo.nl

Bulgaria

Tapflo E00D
Tel: +359 (0)2 974 18 54
office@tapflo.bg

Canada

Tapflo Canada
Tel: +1 514 813 5754
canada@tapflo.com

Croatia

Tapflo d.o.o.
Tel: +385 91 4884 666
sales@tapflo.hr

Czech Republic

Tapflo s.r.o.
Tel: +420 513 033 924
tapflo@tapflo.cz

China

Tapflo (Wuxi)
Tel: +86 510 8241 7072
sales@tapflo.cn

Denmark

Tapflo Danmark
Tel: +45 36 454600
info@tapflo.dk

France

Tapflo France
Tel: +33 1 34 78 82 40
info@tapflo.fr

India

Tapflo Fluid Handling India Pvt Ltd
Tel: +91 20 65000215
ac@tapflo.in

Ireland

Tapflo Ireland Ltd
Tel: +353 1 2011911
info@tapflo.ie

Italy

Tapflo Italia
Tel: +39 0362307698
info@tapfloitalia.com

Japan

Tapflo Japan K.K.
Tel: +81-3-6240-3510
tapflojp@tapflo.co.jp

Kazakhstan

Tapflo Kazakhstan
Tel: +7 727 3278347
sales@tapflo.kz

Netherlands

Tapflo Benelux B.V.
Tel: +31 (0)85 00 743 00
info@tapflo.nl

Poland

Tapflo Sp. z o.o.
Tel: +48 58 530 42 12
info@tapflo.pl

Romania

S.C. Tapflo Rom. S.r.l.
Tel: +40 21 3451255
sales@tapflo.ro

Russia

Tapflo Company
Tel: +7 495 232 18 28
sales@tapflo.com.ru

Serbia

Tapflo d.o.o.
Tel: +381 21 44 58 08
sales@tapflo.rs

Slovakia

Tapflo s.r.o.
Tel: +421 911 137 883
tapflo@tapflo.sk

Slovenia

Tapflo GmbH
Tel: +386 68 613 474
sales@tapflo.hr

Spain

Tapflo Iberica
Tel: +34 91 8093182
avives@tapfloiberica.es

South Africa

Tapflo (Pty) Ltd
Tel: +27 31 701 5255
sales@tapflo.co.za

Turkey

Tapflo Makina Ltd
Tel: +90 216 467 33 11
sales@tapflo.com.tr

Ukraine

TOB Tapflo
Tel: +380 44 222 68 44
sales@tapflo.ua

Uzbekistan

Tapflo Uzbekistan
Tel: +998 712370940
sales@tapflo.uz

United Kingdom

Tapflo (UK) Ltd
Tel: +44 2380 252325
sales@tapflo pumps.co.uk