

IOM manual

tapflo®

Sanitary Series Diaphragm Pumps

Original Instruction

2022 | 1



Read this instruction manual carefully,
before you install and operate the pump



Pump models:

T/TX30
T/TX80
T/TX125
T/TX225
T/TX425
T/TX825



» All about your flow™

www.tapflo.com

CONTENTS

EC DECLARATION OF CONFORMITY 01/EC/SAN/2022	5
EU DECLARATION OF CONFORMITY 01/ATEX/AODD/2022	6
0. GENERAL	7
0.1. Introduction.....	7
0.2. Warning symbols	7
0.3. Qualification and training of personnel.....	7
1. INSTALLATION	8
1.1. Operation principle.....	8
1.2. Receiving inspection	8
1.3. Lifting and transportation.....	9
1.4. Storage.....	9
1.5. Foundation	9
1.6. Suction and discharge piping	9
1.6.1. Connection of suction pipe	10
1.6.2. Connection of discharge pipe	10
1.7. Health and safety	10
1.7.1. Protection	10
1.7.2. Explosion hazardous environments – ATEX.....	11
1.7.3. Air pressure.....	12
1.7.4. Noise level	12
1.7.5. Temperature hazards.....	12
1.8. Air connection	13
1.8.1. Air treatment system	13
1.8.2. Air quality classes.....	13
1.9. Installation example	14
1.10. Recommended installations.....	14
1.10.1. Flooded	14
1.10.2. Self-priming.....	14
2. OPERATION	15
2.1. Before starting the pump.....	15
2.2. Starting and operation	15
2.2.1. Dry running	15
2.2.2. Optimization of the pump lifetime	15
2.3. Pump stopping.....	16
2.4. Cleaning of the pump.....	16

CONTENTS

2.4.1.	CIP – Cleaning In Place	16
2.4.1.1.	Drainage of the pump (T80 – T825)	17
2.5.	Residual risks	17
2.6.	Disposal after expiration of the expected lifetime	17
2.7.	Actions in emergency	17
3.	MAINTENANCE	18
3.1.	When the pump is new or reassembled	18
3.1.1.	Performance test	18
3.2.	Routine inspection	18
3.3.	Complete inspection	18
3.4.	Location of faults	19
3.5.	T30 – Disassembly of the pump	20
3.5.1.	Before the disassembly procedure	20
3.5.2.	Disassembly procedure	20
3.6.	T30 – Assembly of the pump	23
3.6.1.	Test run	24
3.7.	T80-T425 – Disassembly of the pump	25
3.7.1.	Before the disassembly procedure	25
3.7.2.	Disassembly procedure	25
3.8.	T80-T425 – assembly of the pump	29
3.8.1.	Test run	30
3.9.	T825 – Disassembly of the pump	31
3.9.1.	Before the disassembly procedure	31
3.9.2.	Disassembly procedure	31
3.10.	T825 – assembly of the pump	34
3.10.1.	Test run	35
4.	OPTIONS	36
4.1.	Valve options	36
4.1.1.	Flap valves	36
4.1.2.	Ball cup valves	37
4.2.	Heating jacket	37
4.3.	Magnetic ball lifters	38
5.	SPARE PARTS	39
5.1.	T30 – Spare parts drawing	39
5.2.	T30 – Spare parts list	40
5.3.	T80-T125 – Spare parts drawing	41

CONTENTS

5.4.	T80-T125 – Spare parts list.....	42
5.5.	T80 – T125 – Spare parts options	43
5.6.	T225-T425 – Spare parts drawing.....	46
5.7.	T225-T425 – Spare parts list.....	47
5.8.	T225 – T425 – Spare parts options	48
5.9.	T825 – Spare parts drawing	51
5.10.	T825 – Spare parts list	52
5.11.	T825 – Spare parts options.....	53
5.12.	Stocking recommendation	54
5.13.	How to order parts.....	54
5.14.	Pump code	55
6.	DATA	56
6.1.	Capacity curves.....	56
6.2.	Capacity changes.....	57
6.3.	Dimensions	57
6.4.	Technical data	59
6.5.	Tightening torques	59
6.6.	Permitted loads on manifolds.....	59
7.	WARRANTY	61
7.1.	Warranty form.....	61
7.2.	Returning parts	62
7.3.	Warranty	62

EC DECLARATION OF CONFORMITY 01/EC/SAN/2022

Series:

T(...)30...; T(...)80...; T(...)125...; T(...)225...; T(...)425...; T(...)825...;

Manufactured by Tapflo Sp. z o.o., Poland for:

Tapflo Group AB

Filaregatan 4

442 34 Kungälv, Sweden

This declaration of conformity is issued under the sole responsibility of the manufacturer.

Object of declaration: **SANITARY AIR OPERATED DIAPHRAGM PUMPS**

The object of the declaration described above is in conformity with the relevant Union harmonisation legislation:

- Directive 2006/42/EC of European Parliament and of the Council of 17 May 2006 on machinery, amending Directive 95/16/EC;

Mr Michał Śmigiel is authorized to compile the technical file.

Tapflo Sp. z o.o., Poland

ul. Czatkowska 4b

83-110 Tczew



Signed for and on behalf of Tapflo Group AB

A handwritten signature in black ink, appearing to read 'Per Antonsson'.

Per Antonsson
Chief Executive Officer
Kungälv, 16.12.2022

EU DECLARATION OF CONFORMITY 01/ATEX/AODD/2022

Series:

TX(...)9...; TX(...)20...; TX(...)50...; TX(...)100...; TX(...)200...; TX(...)400...; TX(...)800...;
TX(...)25...; TX(...)70...; TX(...)120...; TX(...)220...; TX(...)420...; TX(...)820...;
TX(...)30...; TX(...)80...; TX(...)125...; TX(...)225...; TX(...)425...; TX(...)825...;
TX(...)94...; TX(...)144...; TX(...)244...; TX(...)444...;

Manufactured by Tapflo Sp. z o.o., Poland for:

Tapflo Group AB

Filaregatan 4

442 34 Kungälv, Sweden

This declaration of conformity is issued under the sole responsibility of the manufacturer.

Object of declaration: **CONDUCTIVE AIR OPERATED DIAPHRAGM PUMPS DESIGNED FOR USE IN POTENTIALLY EXPLOSIVE ATMOSPHERES**



The object of the declaration described above is in conformity with the relevant Union harmonisation legislation:

- Directive **2006/42/EC** of European Parliament and of the Council of 17 May 2006 on machinery
- Directive **2014/34/EU** of the European parliament and of the council of 26 February 2014 on Equipment or Protective System intended for use in potentially explosive atmospheres

Applied harmonised standards:

- **EN ISO 80079-36:2016-07**
- **EN ISO 80079-37:2016-07**

ATEX marking:

  **II 2G Ex h IIC T6...T4 Gb**
II 2D Ex h IIIC T54°C...T124°C Db

Notified body **J.S. Hamilton Poland Sp. z o.o.** performed **type examination** and issued certificate **JSHP 19 ATEX 0018X**.

Signed for and on behalf of Tapflo Group AB

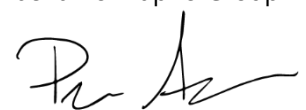

Per Antonsson

Chief Executive Officer

Kungälv, 16.12.2022

0. GENERAL

0. GENERAL

0.1. Introduction

The Tapflo Air Operated Diaphragm Pump range is a complete series of pumps for industrial applications. The pumps are designed to be safe, simple and easy to use and maintain. The construction is seal-less and without rotating parts. The pumps are suitable for a variety of duties in hygienic installations.

With proper attention to maintenance, Tapflo Pumps will give efficient and trouble free operation. This instruction manual will familiarise operators with detailed information about installing, operating and maintaining of the pump.

0.2. Warning symbols

The following warning symbols are present in this instruction manual. This is what they say:



This symbol stands next to all safety instructions in this instruction manual where danger to life and limb may occur. Observe these instructions and proceed with utmost caution in these situations. Inform also other users of all safety instructions. In addition to the instructions in this instruction manual, the general safety and accident prevention regulations must be observed.



This signal stands at points in this instruction manual of particular importance for compliance with regulations and directives, for correct work flow and for the prevention of damage to and destruction of the complete dampener or its subassemblies.

0.3. Qualification and training of personnel



The personnel in charge of installation, operation and maintenance of the pumps we produce must be qualified to carry out the operations described in this manual. Tapflo shall not be held responsible for the training level of personnel and for the fact that they are not fully aware of the contents of this manual. In case any instructions in this manual are unclear or any information is lacking, please contact Tapflo before handling the pump.

1. INSTALLATION

1. INSTALLATION

1.1. Operation principle

The Tapflo diaphragm pump is driven by compressed air. The two diaphragms are connected by a diaphragm shaft and pushed back and forth by alternately pressurising the air chambers behind the diaphragms using an automatically cycling air valve system.

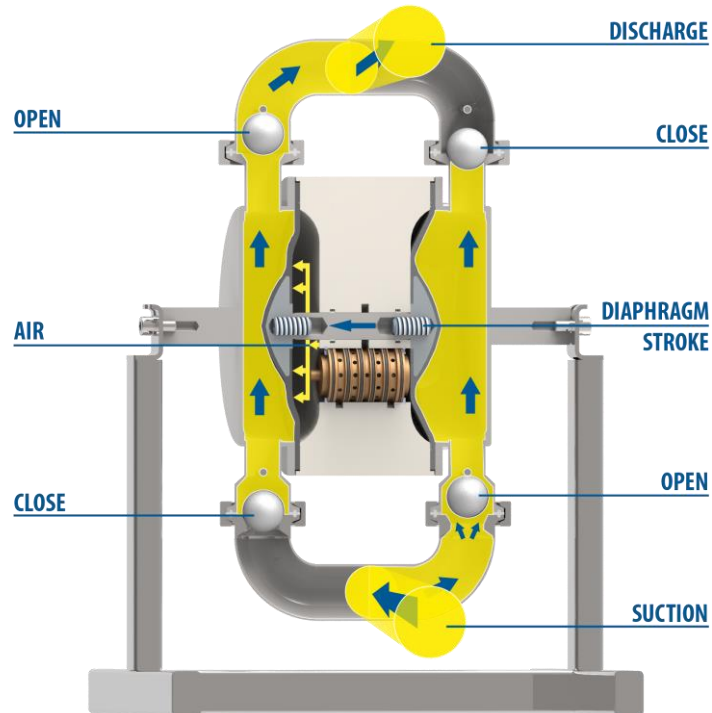

The Suction Cycle:

- **Suction**
One diaphragm creates a suction action in one chamber (on the right) when being pulled back from the housing.
- **Discharge**
The other diaphragm simultaneously transmits the air pressure to the liquid in the second chamber (on the right) of the housing, pushing it towards the discharge port.

During each cycle the air pressure on the back of the discharging diaphragm is equal to the head pressure on the liquid side. Tapflo diaphragm pumps can therefore be operated against a closed discharge valve with no negative effect to the life of the diaphragms.

1.2. Receiving inspection

Although precaution is taken by us when packing and shipping, we urge you to carefully check the shipment on receipt. Make sure that all parts and accessories listed on the packing list are accounted for. Immediately report any damage or shortage to the transport company and to us.

1. INSTALLATION

1.3. Lifting and transportation

Before handling the pump check the weight of the pump (see 6.4. *Technical data*). Refer to Your local standards on how to handle the pump. If the weight is excessive to transport by hand it must be lifted using slings and a suitable lifting device e.g. a crane or forklift.

Always use at least two slings and make sure they are secured in such a way to prevent the pump from slipping and that the pump unit is hanging straight.

Never lift the pump with only one sling. Incorrect lifting can cause serious injury and/or damage to the pump.

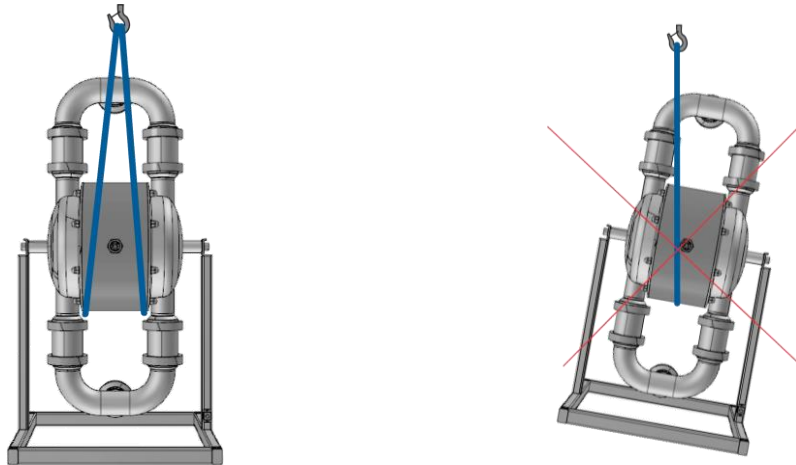

Never lift the pump under pressure.

Be careful that nobody passes under the pump when lifted.

Never try to lift the pump by the hoses attached to the pump.

As an option pumps can be equipped with lifting eyebolts connected with the pump housing.

1.4. Storage



If the equipment is to be stored prior to installation, place it in a clean location. The pump should be stored in an ambient temperature of 15°C (59°F) to 25°C (77°F) and relative humidity below 65%. It should not be exposed to any heat source e.g. radiator, sun as this could result in a negative way on the tightness of the pump. Do not remove the protective covers from the suction, discharge and air connections which have been fastened to keep pump internals free of debris. Clean the pump thoroughly before installation.

1.5. Foundation



The support of the pump is furnished with mounting holes. Fix the pump on a stable foundation, which is able to absorb vibrations. It is essential for the operation of the pump to mount the pump with the feet in a downward direction (see in chapter 1.10 "Recommended installations").

1.6. Suction and discharge piping

Suction and discharge piping should be fully supported and anchored near to but independent of the pump. The piping to the pump should be a hose, to prevent undue stress and strain on the pump connections and the piping.

1. INSTALLATION

1.6.1. Connection of suction pipe

Remember that the suction pipe/connection is the most critical point, especially if the pump is priming. Just a small leakage will dramatically reduce the suction capability of the pump. When connecting the suction pipe, following is recommended.

- 1) For satisfactory operation, use reinforced hose (the suction power may otherwise shrink the hose) or other flexible piping. The internal diameter of the hose should be the same as on the suction connection (at the bottom of the pump) to have best suction capability.
- 2) Make sure that the connection hose - pump is completely tight, otherwise the suction capability will be reduced.
- 3) Always use as short suction pipe as possible. Avoid air pockets which can arise with long piping.

1.6.2. Connection of discharge pipe

For this connection it is only recommended a simple and positive flow connection. Use a hose or flexible piping (minimum one meter) between the discharge connection and any rigid fixed piping. Coil the hose at least one turn. All components (hose, pipe, valves etc.) on the discharge piping must be designed for minimum PN 10.

1.7. Health and safety

The pump must be installed according to local and national safety rules.



The pumps are constructed for particular applications. Do not use the pump on applications different from that for which it was sold without consulting us to ascertain its suitability.

1.7.1. Protection



In the interest of health and safety it is essential to wear protective clothing and safety goggles when operating, and/or working in the vicinity of Tapflo pumps.

1. INSTALLATION

1.7.2. Explosion hazardous environments – ATEX



The standard Sanitary series pumps are not allowed to operate in environments where there is danger of explosion. Static electricity may occur in the pump under operation, which may cause explosion and injury. Special conductive TX pumps are available for such applications. Follow below instructions and local/national rules for safe use.

ATEX (directive 2014/34/EU) classification of Tapflo TX pumps:

II 2G Ex h IIC T6...T4 Gb

II 2D Ex h IIIC T54°C...T124°C Db

- Equipment group: **II** – all other explosive areas than mines;
- Category group: **2** – high level of protection (can be used in zone 1);
- Atmosphere: **G** – gas;
D – dust;
- Explosion group: **IIC** – gas group (such as acetylene, hydrogen);
IIIC – dust group (conductive dusts);
- Type of protection: **h** – control of ignition sources;
- Temperature class: **T4, T6** – in the event of a malfunction, the maximum temperature of a surface that may be exposed to gas **T4** = 135°C, **T6** = 85°C;
- EPL protection level: **Gb, Db** – high protection.



Temperature classes and allowable temperatures

The temperature class of the pump depends on the temperature of the pumped medium and ambient temperature. Ambient temperature range depends on pump configuration, follow pump nameplate for allowable range. Contact Tapflo for more information.

Medium temp.	Temperature class / Surface temperature	Temperature class / Surface temperature	Temperature class / Surface temperature
	-20°C ≤ Ta ≤ +40°C	-20°C ≤ Ta ≤ +50°C	-20°C ≤ Ta ≤ +60°C
40°C	T6 / T54°C	T6 / T64°C	T6 / T74°C
50°C	T6 / T64°C	T6 / T64°C	T6 / T74°C
60°C	T6 / T74°C	T6 / T74°C	T6 / T74°C
70°C	T6 / T84°C	T6 / T84°C	T6 / T84°C
80°C	T5 / T94°C	T5 / T94°C	T5 / T94°C
90°C	T4 / T104°C	T4 / T104°C	T4 / T104°C
100°C	T4 / T114°C	T4 / T114°C	T4 / T114°C
110°C	T4 / T124°C	T4 / T124°C	T4 / T124°C



Earth connection of the pump and other equipment

Connect a suitable earth wire to the stainless steel earth connection that is placed on the inside of one of the pump housings. Connect the other end of the earth wire to earth and also make sure that other equipment like hoses/pipes/containers etc. are properly earthed/connected.



Antistatic surface

Pumps in ATEX execution should be cleaned in order to preserve antistatic properties. Layer of dust or other solid particles on the outer surfaces is unacceptable

1. INSTALLATION

Dry run in ATEX pump

ATEX approved pumps can run dry without increasing the risk of creating potential ignition sources. Nevertheless, dry run periods should be decreased to minimum as they increase the wear of parts inside of the pump. What is more, when running dry (e.g. during self-priming) the pump should run at a low speed controlled via a needle valve.

1.7.3. Air pressure



The maximum air pressure for Tapflo pumps is 8 bar. Higher air pressure than 8 bar can damage the pump and may cause injury to personnel in vicinity of the pump. If you intend to apply a higher air pressure than 8 bar, please consult us.

1.7.4. Noise level



At tests, the noise level from a Tapflo pump has not exceeded 85 dB(A). Under some circumstances, for example if the pump is operating under high air pressure at low discharge head, the noise can be inconvenient or hazardous for personnel staying for long periods in the vicinity of the pump. This hazard can be prevented by:

- using suitable ear protection;
- lowering the air pressure and/or raising the discharge head;
- leading out the outgoing air from the room by connecting a hose to the muffler connection of the pump;
- using elastomer valve balls (EPDM, NBR or polyurethane) instead of PTFE, ceramic or stainless steel, provided that the elastomer is compatible with the pumped liquid.

1.7.5. Temperature hazards



➤ Raised temperature can cause damage on the pump and/or piping and may also be hazardous for personnel in the vicinity of the pump/piping. Avoid quick temperature changes and do not exceed the maximum temperature specified when the pump was ordered. See also general max temperatures based on water in chapter 6. "DATA".



➤ When the pump is exposed to ambient temperature variations or if there is big difference between the temperature of the product and the surrounding, the tightening torques of the housing nuts should be checked periodically as part of preventive maintenance. **Please contact Tapflo for tightening intervals recommendation.**



➤ If a hot product is pumped, the pump should not stand still when filled for a longer period of time. This could cause leakage from the valves and contamination and/or damage of the air valve.



➤ Below 0°C (32°F) plastic materials become more fragile what can cause accelerated wear of parts made of these materials. This is a hazard that has to be accepted when pumping such cold products. Also in such case, when a pump is not operational it should be drained of all liquid.



➤ Bear in mind that the viscosity of the product changes with temperature. This has to be taken into consideration when selecting the pump.

1. INSTALLATION

1.8. Air connection

Screw the air hose into the air intake on the centre block of the pump with for example a bayonet coupling. For best efficiency, use the same hose diameter as the internal diameter of the connection on the air intake.

1.8.1. Air treatment system



The air valve is constructed for oil-free air. Lubrication of the air is **not allowed**. However, if the air is **very dry** (laboratory air), we recommend to use a plastic air valve. Maximum air pressure is 8 bar. As prevention purpose, a filtration of the air by means of a 5 micron filter or finer is recommended. Recommended air quality according to PN-ISO8573-1:2010 is particles class 6, water class 4 and oil class 4. Dirt in the air can under unfortunate circumstances be the cause of a breakdown.

To facilitate the operation of the pump we recommend an air treatment system connected to the air supply. These components should be included:

- 1) Regulator to adjust the air pressure;
- 2) Manometer to read the actual pressure;
- 3) Needle valve to adjust the air flow (especially when operating the pump in the lower range of performance);
- 4) Filter.

These components are included in Tapflo's **Air treatment system** which can be ordered from us.

1.8.2. Air quality classes

ISO 8573-1:2010 Compressed Air Contaminants and Purity Classes

Class	Solid particles			Mass concentration [mg/m ³]	Water		Oil Total oil content (liquid, aerosol and vapour) [mg/m ³]
	Maximum number of particles per m ³		Pressure dew point [°C]		Liquid [g/m ³]		
	0.1 – 0.5 µm	0.5 – 1 µm				1 – 5 µm	
0	As specified by the equipment user or supplier and more stringent than class 1						
1	≤ 20,000	≤ 400	≤ 10	–	≤ –70	–	0.01
2	≤ 400,000	≤ 6,000	≤ 100	–	≤ –40	–	0.1
3	–	≤ 90,000	≤ 1,000	–	≤ –20	–	1
4	–	–	≤ 10,000	–	≤ +3	–	5
5	–	–	≤ 100,000	–	≤ +7	–	–
6	–	–	–	≤ 5	≤ +10	–	–
7	–	–	–	5 – 10	–	≤ 0.5	–
8	–	–	–	–	–	0.5 – 5	–
9	–	–	–	–	–	5 – 10	–
X	–	–	–	> 10	–	> 10	> 10

1. INSTALLATION

1.9. Installation example

- 1) Gate valve compressed air
- 2) Filter and pressure regulator
- 3) Flexible hose
- 4) Needle valve
- 5) Flexible piping
- 6) Gate valve suction
- 7) Gate valve discharge
- 8) Coiled flexible piping
- 9) Flow gauge

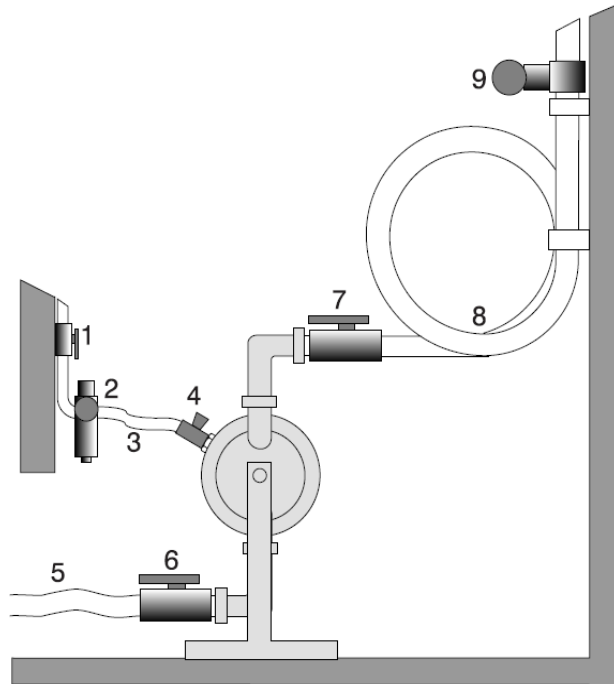

1.10. Recommended installations

The Tapflo pump is flexible in the way you are able to install it.

1.10.1. Flooded



The piping system is designed with a positive suction head. This is the best way of installation where it is necessary to completely evacuate all liquid from the container, or where viscous (thick) products are transferred.

NOTE! Do not exceed 0,7 bar suction pressure! Higher pressure may cause premature diaphragm failure and irregular pump operation.

1.10.2. Self-priming

The Tapflo pump is designed to pull a high vacuum. It is able to evacuate an empty suction pipe without any damage to the pump. The suction lift is up to 5 meters (16.4 ft.) from an empty suction pipe and up to 8 meters (26.2 ft.) from a wetted pipe. The suction capability depends on the pump size (see chapter 6. "Data").



NOTE!

Even if all above safety instructions are met and complied with, there still exists a minor danger in the event of a leakage or mechanical damage of the pump. In such case the pumped product can emerge on sealing areas and connections.

2. OPERATION

2. OPERATION

2.1. Before starting the pump



- Make sure the pump is installed according to the installation instruction (chapter 1).
- Fully open all valves on suction line. Leaving the suction valve closed leads to premature diaphragm failure.



- When installation is new or reinstalled, a test run of the pump with water should be conducted to make sure that the pump operates normally and does not leak.
- When installation is new or reinstalled, check the pump housing nuts tightening torque (see chapter 6.5 "Tightening torques"). After approximately one week of operation, the torque should be checked again. **Contact Tapflo for further tightening intervals recommendation.** This is important to prevent possible leakage.

2.2. Starting and operation

- Open the discharge valve.
- **Note! Considering the suction capacity when air is still in the suction pipe, it is recommended to start with low air pressure/flow (slowly) at the beginning. This is not necessary if the pump is filled with liquid before start.**
- When the pump has been filled with liquid, the air pressure/flow may be raised in order to increase the suction capacity of the pump.
- The performance of the pump can be adjusted through the air supply by using a needle valve and a pressure regulator. The performance can also be adjusted by normal flow control on the discharge side of the system.

2.2.1. Dry running

Although the pump is prepared for dry running it is important to have in mind that long periods of dry run may cause damage to the air valve and circlips. Also an empty pump should operate at low speeds – controlled by a needle-valve.

2.2.2. Optimization of the pump lifetime



- Running at full frequency (maximum air pressure/flow) continuously will cause premature wear of the components. When there is possibility of the pump running dry or/and at full frequency it is recommended to use an air valve with a PET piston. As a general rule, we recommend to run at half of the maximum capacity of the pump. For instance, a T80 pump should run continuous at maximum 40 l/min.
- As stated in chapter 1.8.1 Tapflo recommends to use an appropriate air treatment system in order to extend the pump's lifetime.
- If the air humidity is high, use of a water separator or air dryer is recommended. Otherwise on the air discharge side due to decompression, icing on the muffler can appear causing it to shrink and eventually it can shoot out of its socket.

2. OPERATION

- If the ambient air is humid, icing can occur outside of the muffler. In such case it is recommended to use a longer exhaust of the compressed air (ca. 500 mm / 19,7").
- If icing / freezing is still a problem with the standard muffler, we recommend using our heavy duty metal muffler. Contact us for more information.

2.3. Pump stopping

The pump can be stopped in two ways:

- 1) By closing of the discharge valve. The pressure from the system will stop the pump automatically. The pump restarts easily when the valve is opened again.
NOTE! When using this method keep in mind that air must be supplied to the pump. This is essential to keep the diaphragms in balance what protects them from premature failure.
- 2) By cutting off the air supply.
NOTE! When using this method make sure that the discharge valve is opened to relief the pumps pressure.

2.4. Cleaning of the pump

2.4.1. CIP – Cleaning In Place



The importance of easy cleaning is essential in hygienic applications. Tapflo aseptic pumps are designed for CIP (Cleaning In Place) and SIP (Sterilization In Place). This allows the pump to be internally cleaned without disassembly. The pump can be cleaned by flushing through with a CIP fluid (usually a mild solution of sodium hydroxide and a sanitizing additive) or by injection of hot steam (SIP). Despite the general temperature restriction (see 6.4. "Technical data"), a brief operation (max. 30 minutes) at 130°C (266°F) for sterilization process is permitted. Make sure that the CIP fluid is compatible with the materials in the pump/piping.

During CIP and SIP pump must run slowly (1-2 strokes per second) to obtain pressure balance on both sides of the diaphragm. Lack of pressure balance will have influence on the pump's lifetime. Direction of the forced flow should be, the same as during normal operation, from the inlet to the outlet. Contact us for more information.

2. OPERATION

2.4.1.1. Drainage of the pump (T80 – T825)

After the CIP procedure, the pump usually has to be drained from the CIP fluid. The Tapflo sanitary series is supplied with a hygienic stand, enabling 360° rotation of the pump unit.

- 1) Disconnect the pump from the piping.
- 2) Simply loosen the two socket head cap screws (pos. 174 – see chapter 5. "SPARE PARTS"), rotate the pump 180° and let the remaining fluid drain off. The airline may be left connected during this operation.
- 3) Rotate back to normal position, connect the pump with the piping and fix the socket head cap screws (pos. 174).

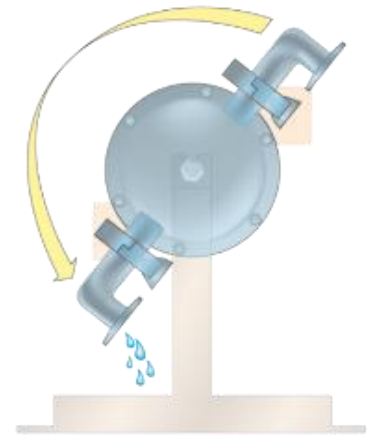

2.5. Residual risks

Even with proper application and observance of all points listed in this operating manual, there is still an estimable and unexpected residual risk when using the pumps. It may leak, fail due to wear, application-related causes or system-related circumstances.

2.6. Disposal after expiration of the expected lifetime

The metallic components like aluminium, stainless steel and carbon steel can be recycled. Plastic parts are not recyclable and must be disposed of as residual waste. The pump must be disposed of properly, according to local regulations. It should be noted that potentially dangerous fluid residues may remain in the pump and can create a hazard to the operator or the environment, therefore the pump has to thoroughly cleaned before disposal.

2.7. Actions in emergency



In the event of a leak during fluid transfer, the air supply have to be closed and the pressure released. During spillage of an aggressive liquid, local and national safety rules must be followed.

3. MAINTENANCE

3. MAINTENANCE

3.1. When the pump is new or reassembled



If the pump is new or reassembled after maintenance it is important to retighten the pump housing nuts (pos. 37) after approximately one week of operation. Make sure to use the right torque – see chapter 6.5 “*Tightening torques*”.

3.1.1. Performance test

When installation is new, a test run of the pump should be conducted. Gauge the capacity at specific air pressure/flow. This information is useful for checking performance in the future as wear takes place. You will be able to set schedules for maintenance of the pump and to select spare parts to be kept on stock.

3.2. Routine inspection



Frequent observation of the pump operation is recommended to detect problems. Leaking air or liquid from the pump and changes of performance, as well as abnormal noises, can be indication of worn parts or pump malfunction (see chapter x.x ““Location of faults””).

We recommend to conduct a daily check and keep records of the following:

- Any leakage from the pump
- Tightness of all pump fasteners
- Complete inspection in regular intervals has been done

In case any of the above is not fulfilled, do not start the pump and implement corrective actions. Establish a preventive maintenance schedule based on the pump’s service history. Scheduled maintenance is especially important to prevent spills or leakage due to diaphragm failure.

3.3. Complete inspection



The intervals for a complete inspection depend upon the operation conditions of the pump. The characteristics of the liquid, temperature, materials used in the pump and running time decide how often a complete inspection is necessary.

Nevertheless, Tapflo recommend to inspect the pump at least once a year and change parts from KIT AIR and KIT LIQ during this inspection. See chapter x.x “Stocking recommendation” for detailed KIT content.

3. MAINTENANCE

3.4. Location of faults

PROBLEM	POSSIBLE FAULT	POSSIBLE SOLUTION
The pump does not run	The air pressure is too low The air connection is blocked Muffler is blocked Air valve is defective Dirt in the pump chamber Diaphragm breakdown	Increase air pressure via a filter-regulator Check / clean air supply connection Check / clean / replace muffler Clean / replace complete air valve Remove debris from the chambers Replace diaphragm
The suction is bad	Suction connection is not tight Suction connection is blocked Muffler is blocked Valve balls are blocked or damaged Valve seats are worn Pump starts with high pressure Air in suction / discharge line Dry suction against discharge pressure	Tighten the suction line Clean suction line Check / clean / replace muffler Check dimensions and shape of valve balls Check dimensions and shape of valve seats Start the pump slowly (see chapter 2.2) Vent suction / discharge line Wet the pump / start without discharge pressure
The pump runs irregular	Valve balls are blocked Sealing in centre block Air valve is defective Diaphragm breakdown Valve seats are worn Icing on the muffler	Check dimensions and shape of valve balls Replace sealing Clean / replace air valve Replace diaphragm Check dimensions and shape of valve seats Improve air quality (see chapters 1.7.1 and 2.2.2)
Bad flow/pressure	Pressure fall in air supply Pressure losses on suction side Air supply / air valve leaking Suction or air connection blocked Muffler is blocked Valve ball worn or broken Valve seats are worn Air in liquid Diaphragm breakdown Icing on the muffler	Increase air pressure via a filter-regulator Check/change installation on suction side Check / repair / replace air supply / air valve Check / clean air supply / suction connection Check / clean / replace muffler Check dimensions and shape of valve balls Check dimensions and shape of valve seats Seal suction line; check / refill container Check / replace diaphragms Improve air quality (see chapters 1.7.1 and 2.2.2)
Liquid leaks from the pump	Screws on the housing not properly tightened O-rings on manifolds damaged Damaged diaphragm Tension / stress from the installation	Check tightening torques of the screws Replace O-rings Check / replace diaphragms Adjust installation, eliminate stress, when using a dampener provide separate support for it (see dampener IOM manual).
Liquid comes out of the muffler	Diaphragm breakdown	Replace diaphragm
Diaphragm breakdown	Wrong selection of material Too high pressure in the installation Long periods of dry running Too high pressure on suction side	Contact us for information on material selection Use air treatment system for protection When dry, run pump slowly (see chapter 2.2) Make sure there is pressure balance between the air and liquid side of the diaphragm

3. MAINTENANCE

3.5. T30 – Disassembly of the pump

The numbers put in brackets, refer to the part numbers in the spare part drawings and spare part lists in chapter 5 "SPARE PARTS".

3.5.1. Before the disassembly procedure



Be sure to drain all liquid from the pump. Cleanse or neutralize the pump thoroughly. Disconnect the air supply and then the suction and discharge connections.

3.5.2. Disassembly procedure

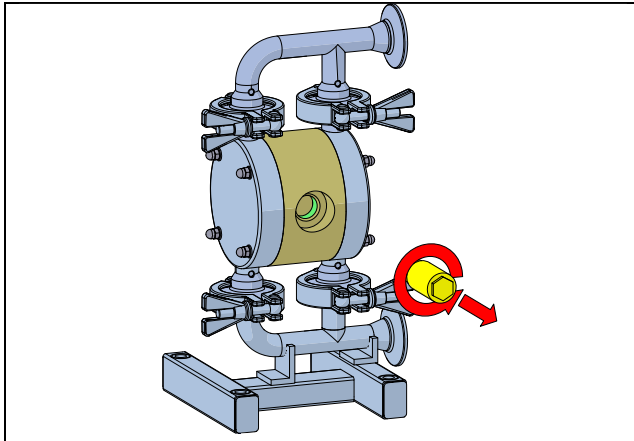

Fig. 3.5.1
Unscrew and remove muffler [25].

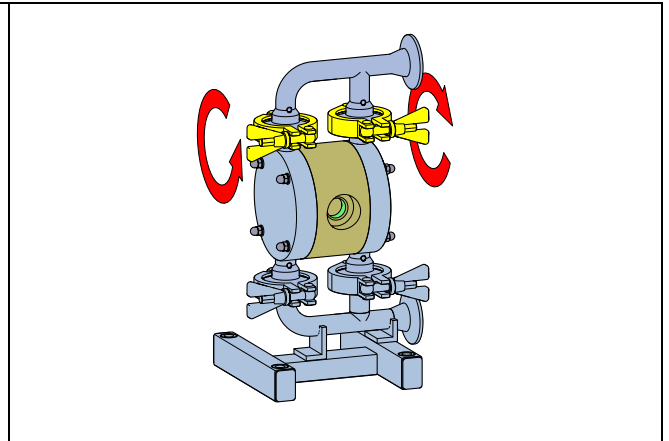

Fig. 3.5.2
Unscrew and remove two tri-clamps [138] connecting the outlet manifold [132] to the housings [11].

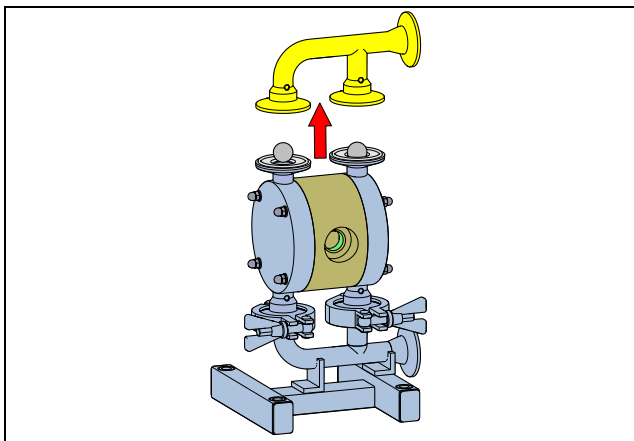

Fig. 3.5.3a
Take off the outlet manifold [132].

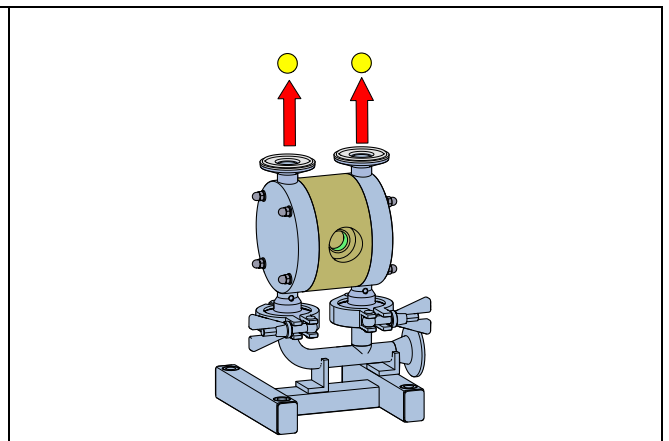

Fig. 3.5.3b
Remove the valve balls [23].

3. MAINTENANCE

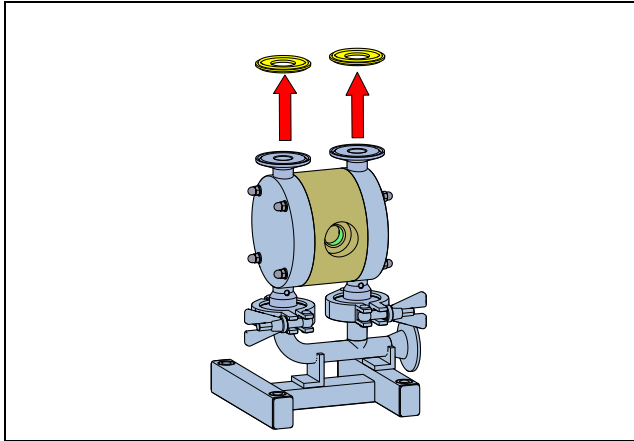

Fig. 3.5.3c
Remove the sealing [18].

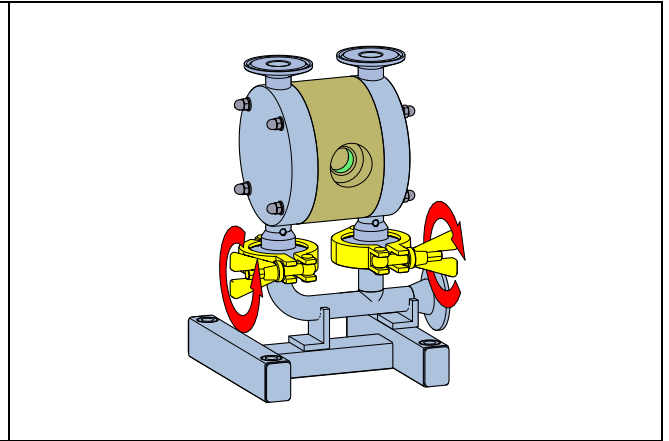

Fig. 3.5.4
Unscrew and remove two tri-clamps [138] connecting the inlet manifold and stand [131] to the housings [11].

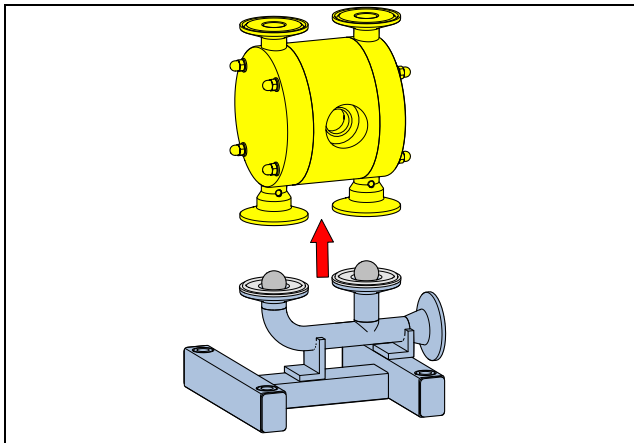

Fig. 3.5.5
Take the centre block [12] and housing [11] assembly of the inlet manifold and stand.

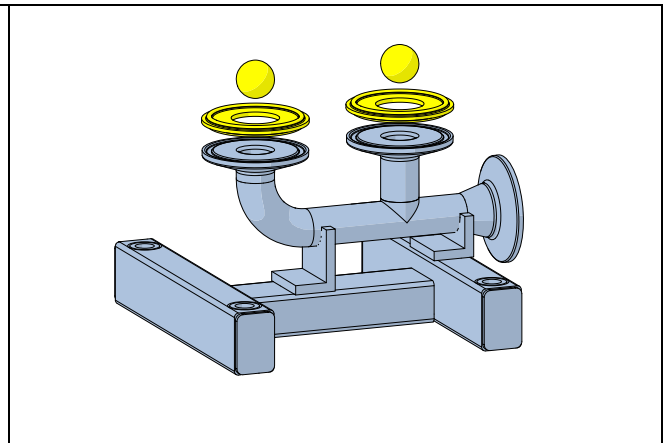

Fig. 3.5.6
Remove the valve balls [23] and sealing [18].

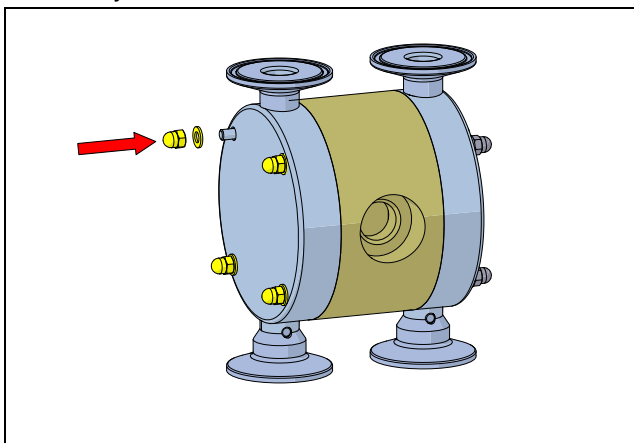

Fig. 3.5.7
Unscrew the domed nuts [37].

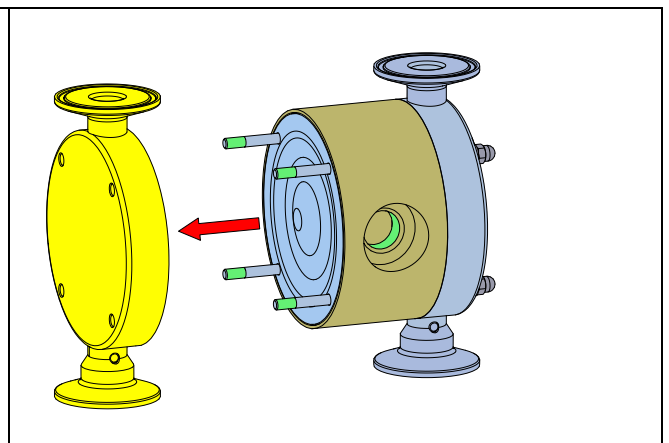

Fig. 3.5.8
Remove the housing [11] from one side of the pump.

3. MAINTENANCE

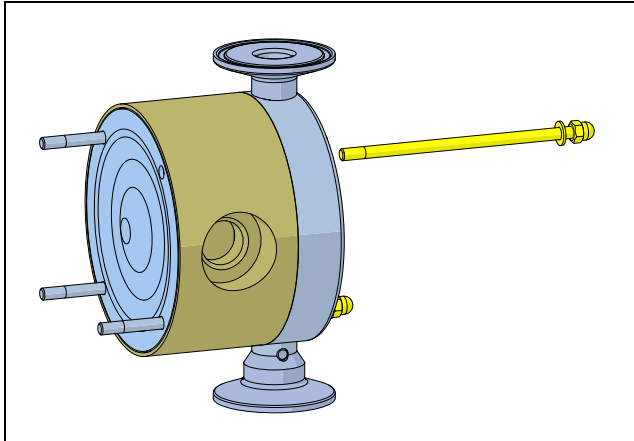

Fig. 3.5.9
Remove the domed nuts [37], stud bolts [14] and washers [38].

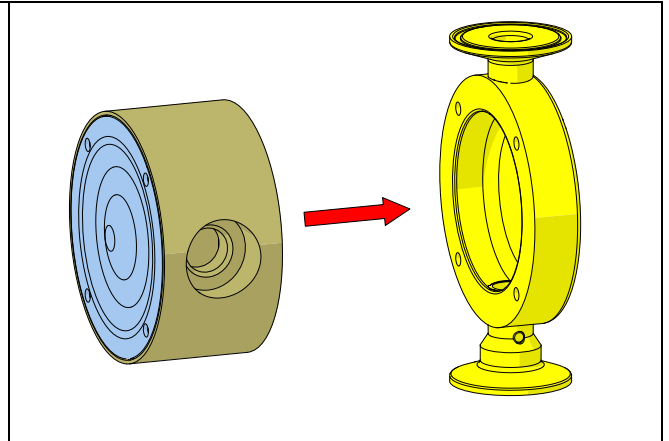

Fig. 3.5.10
Take off the second housing [11].

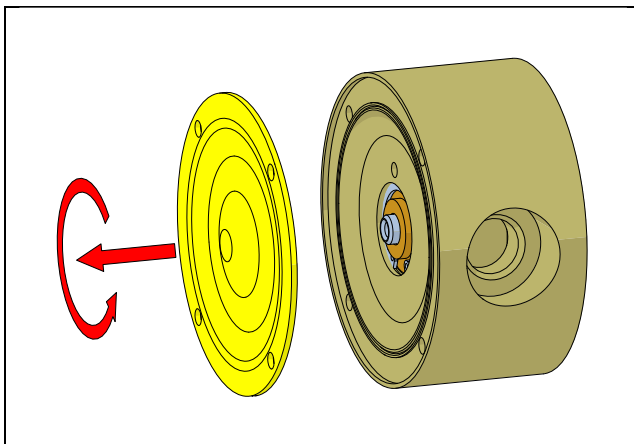

Fig 3.5.11
Unscrew the diaphragm [15].

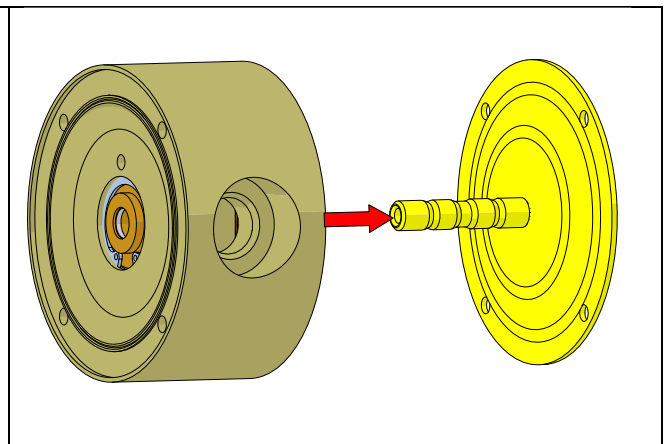

Fig 3.5.12
Take out the second diaphragm [15] along with the shaft [16].

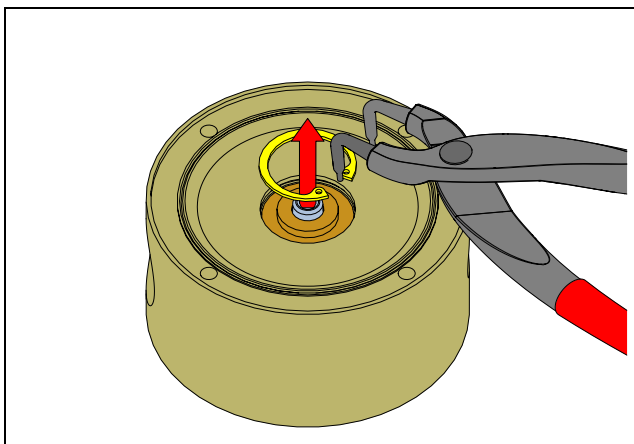

Fig 3.5.13
Using circlip pliers remove both circlips [27] from the centre block [12].
Attention! While doing this, cover yourself with your other hand, as the circlip easily flips away

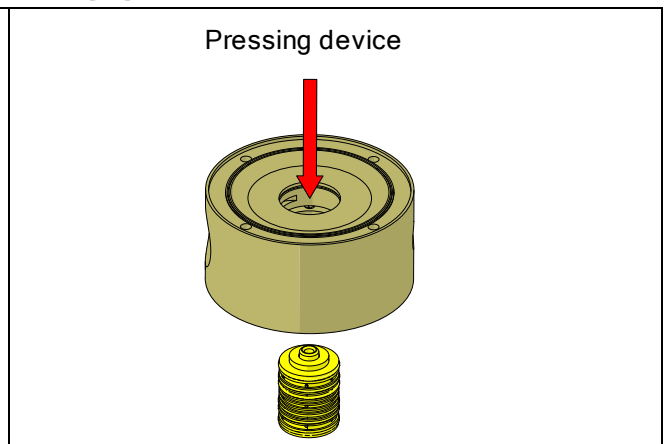

Fig 3.5.14
Press out the air valve [61] by means of a pressing device. Be careful not to damage the brass edges of the air valve.

3. MAINTENANCE

The pump is now completely disassembled. Check all components for wear or damage and replace if necessary.

When air valve is removed from the centre body check the external O-rings (pos. 30) condition and replace if necessary.

3.6. T30 – Assembly of the pump

The assembly procedure is done in the reverse order to the disassembly.

Nevertheless there are a few things that you have to remember in order to assemble the pump correctly.

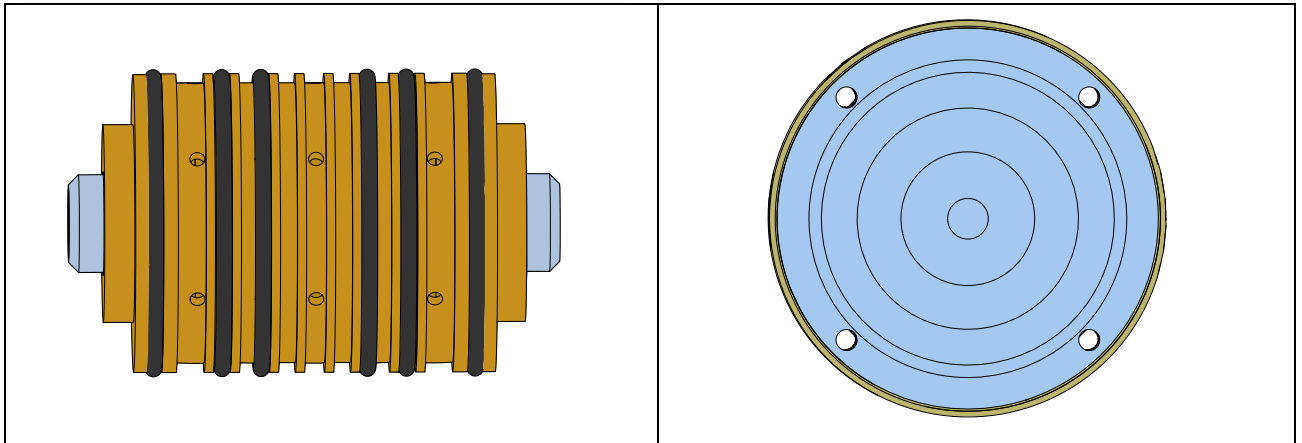

Fig. 3.6.1

When putting the air valve [61] into the centre block [12], apply some water or alcohol on the O-rings to provide smooth insert of the air valve. It is recommended to use a pressing device for this operation.

NOTE! When inserting the T30 size air valve, replace the shaft with a screw and a nut to make sure the air valve assembly remains properly fastened.

Fig. 3.6.2

When screwing in the diaphragms [15] on the shaft [16], the holes in the diaphragms must align with the holes in the centre block [12]. Sometimes it is necessary to turn the diaphragm back a little bit in order to align the holes.

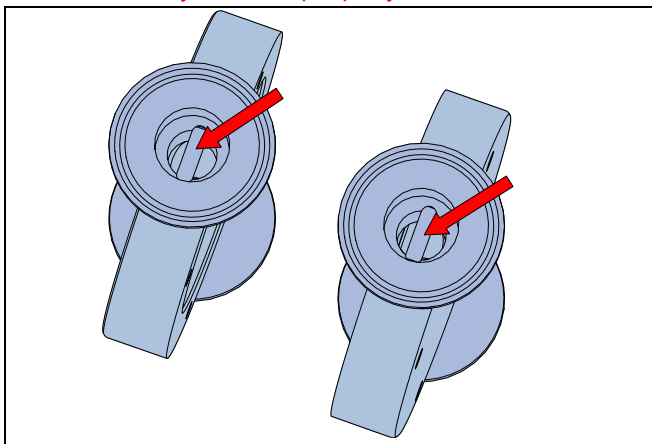

Fig. 3.6.4

During assembly of the housings [11] make sure they are in the correct position – the inlet pipe has a valve ball stopper.

3. MAINTENANCE

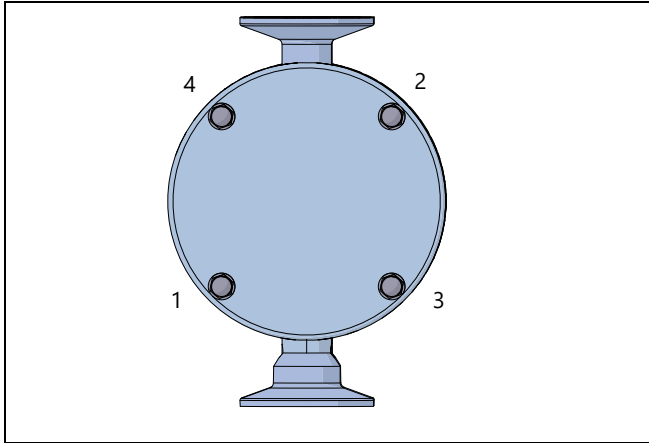

Fig. 3.6.5

When fastening the domed nuts, remember to do it with correct order and with the appropriate torque.

NOTE! Keep in mind to periodically retighten stud bolt's nuts.

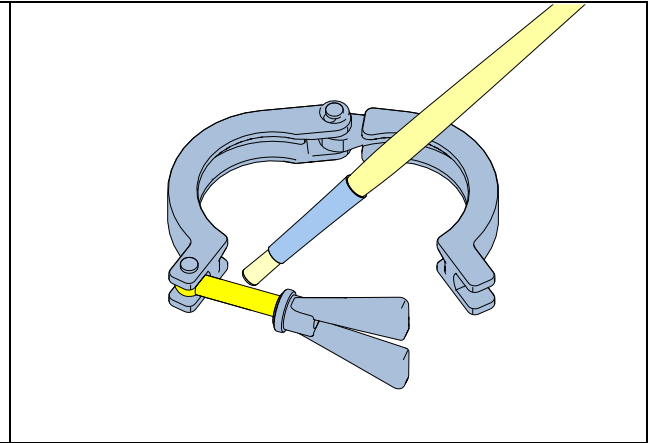

Fig. 3.6.6

When fastening the tri-clamps apply some FDA grade lubricant on the thread.

3.6.1. Test run



We recommend you to conduct a test run of the pump before installing it in the system, so no liquid gets wasted if the pump leaks or perhaps does not start accordingly to wrong assembly of the pump.

After one week of operation retighten the nuts with appropriate torque.

3. MAINTENANCE

3.7. T80-T425 – Disassembly of the pump



The numbers put in brackets, refer to the part numbers in the spare part drawings and spare part lists in chapter 5 "SPARE PARTS".

3.7.1. Before the disassembly procedure

Be sure to drain all liquid from the pump. Cleanse or neutralize the pump thoroughly. Disconnect the air supply and then the suction and discharge connections. Due to size and weight, two persons are required to conduct service.

3.7.2. Disassembly procedure

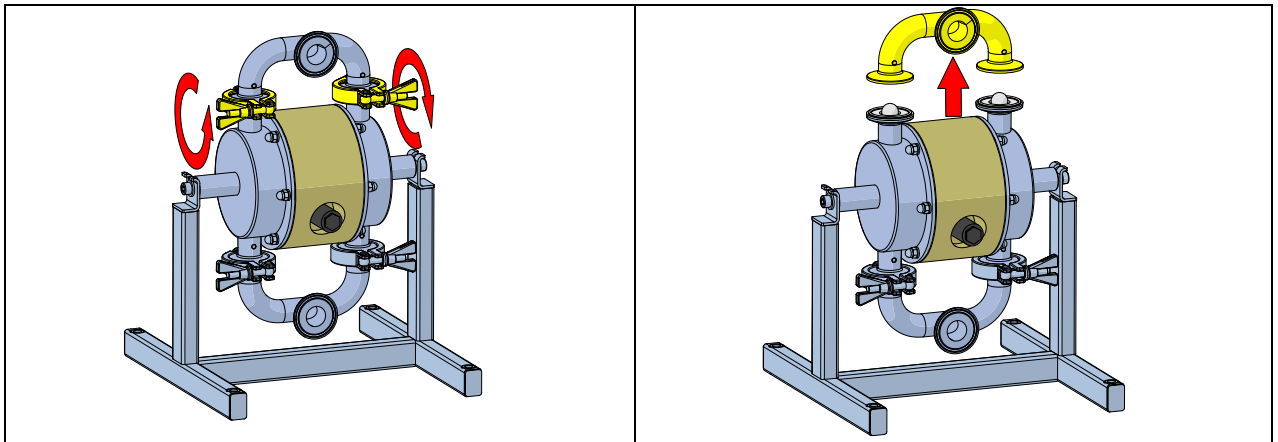

Fig. 3.7.1

Unscrew and remove two tri-clamps [138] connecting the manifold [132] to the housings [11].

Fig. 3.7.2a

Take off the manifold [132].

3. MAINTENANCE

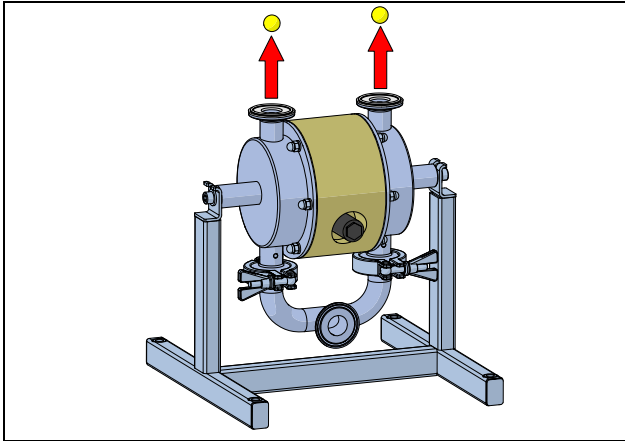

Fig. 3.7.2b
Remove the valve balls [23].

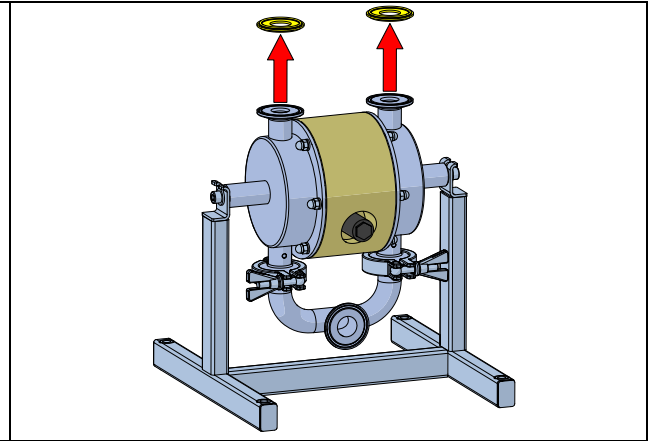

Fig. 3.7.2c
Remove the sealing [18].

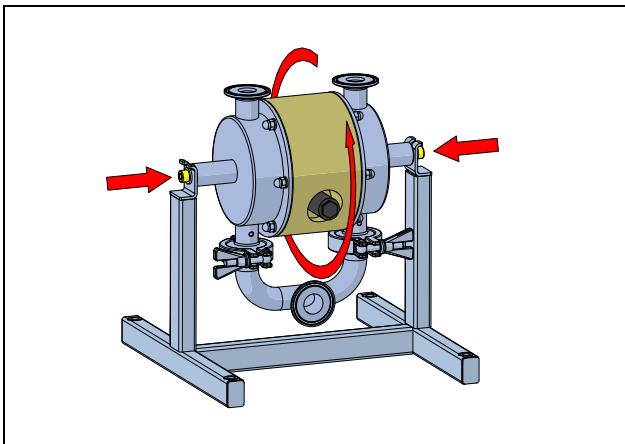

Fig. 3.7.3
Loosen the socket head cup screws [174] and rotate the pump, after that repeat the steps shown in the figures 3.7.1 and 3.7.2 a, b, c .

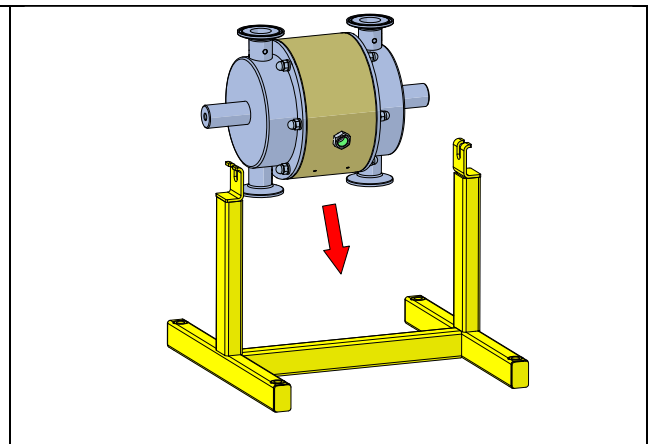

Fig. 3.7.4
Remove the socket head cap screws [174] and take off the pump from the stand [17].

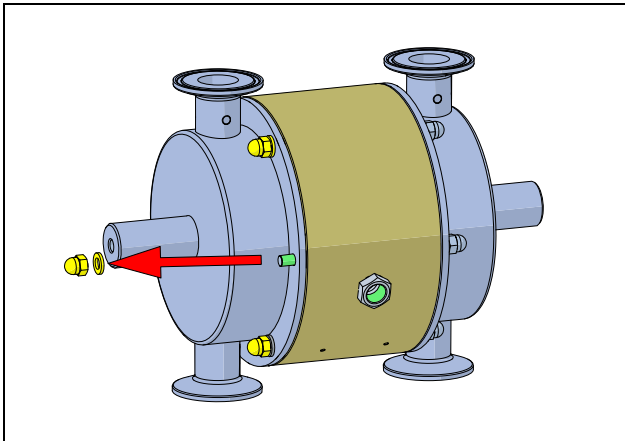

Fig. 3.7.5
Unscrew the domed nuts [37].

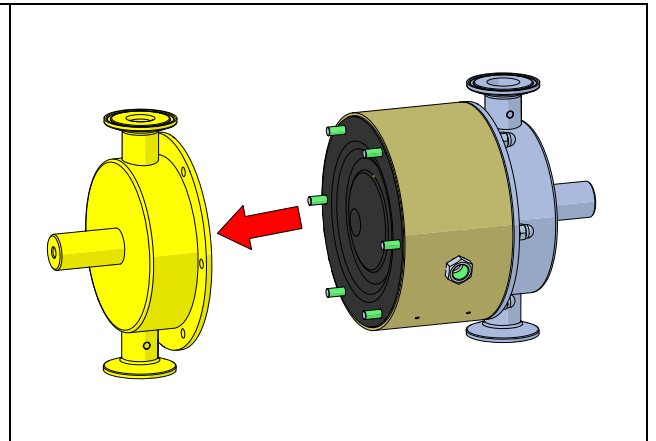

Fig. 3.7.6
Remove the housing [11] from one side of the pump.

3. MAINTENANCE

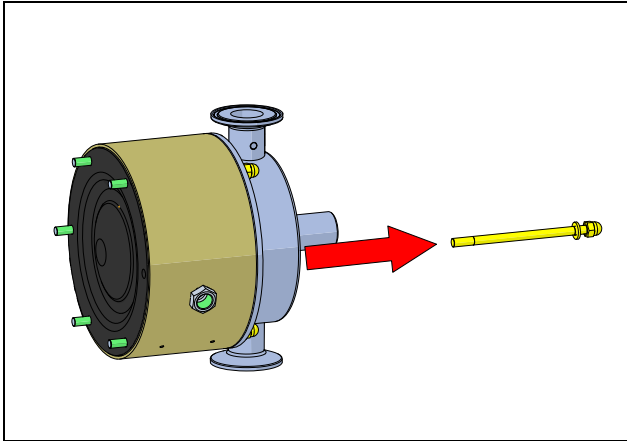

Fig. 3.7.7
Remove the domed nuts [37], stud bolts [14] and washers [38].

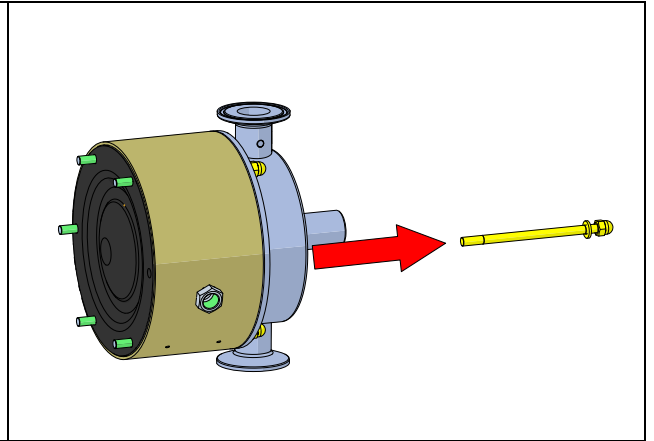

Fig. 3.7.8
Take off the second housing [11].

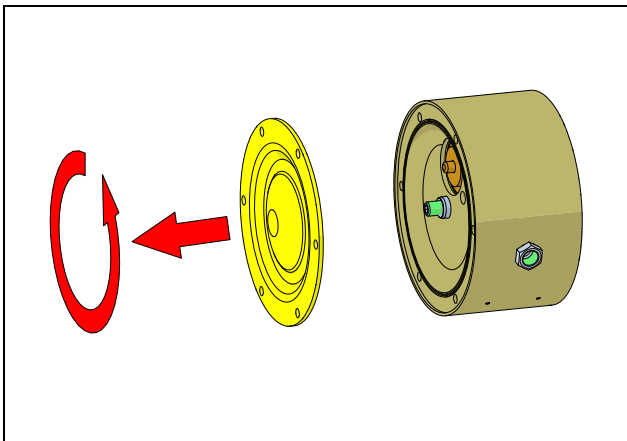

Fig. 3.7.9
Unscrew the diaphragm [15] from one side of the pump.

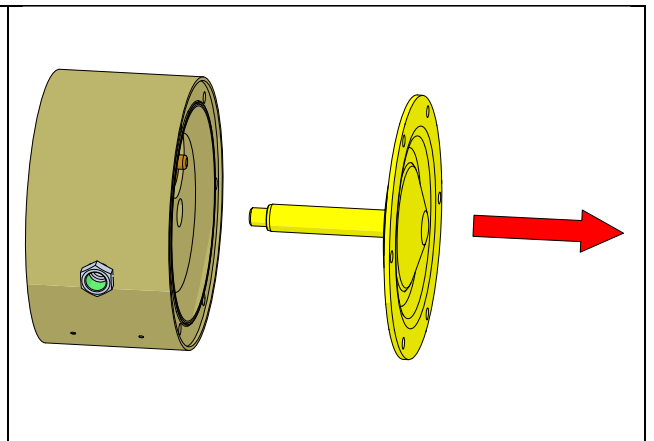

Fig. 3.7.10
Take out the second diaphragm [15] along with the shaft [16].

a) Circlip mounted air valve – T/TX80, T125

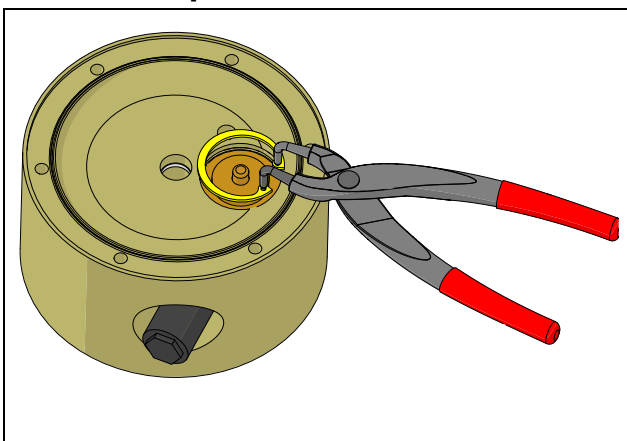

Fig. 3.7.11
Using circlip pliers remove both circlips [27] from the centre block [12].
Attention! While doing this, cover yourself with your other hand, as the circlip easily flips away.

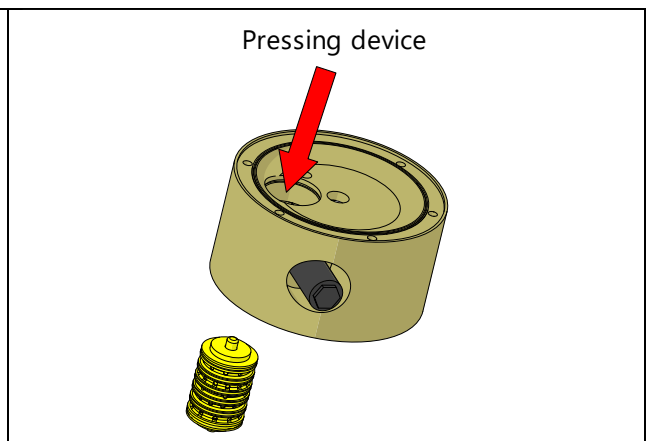

Fig. 3.7.12
Press out the air valve [61] by means of a pressing device. Be careful not to damage the brass edges of the air valve.

3. MAINTENANCE

b) Plate mounted air valve – TX125 from s/n 0907-..., T/TX225, T/TX425

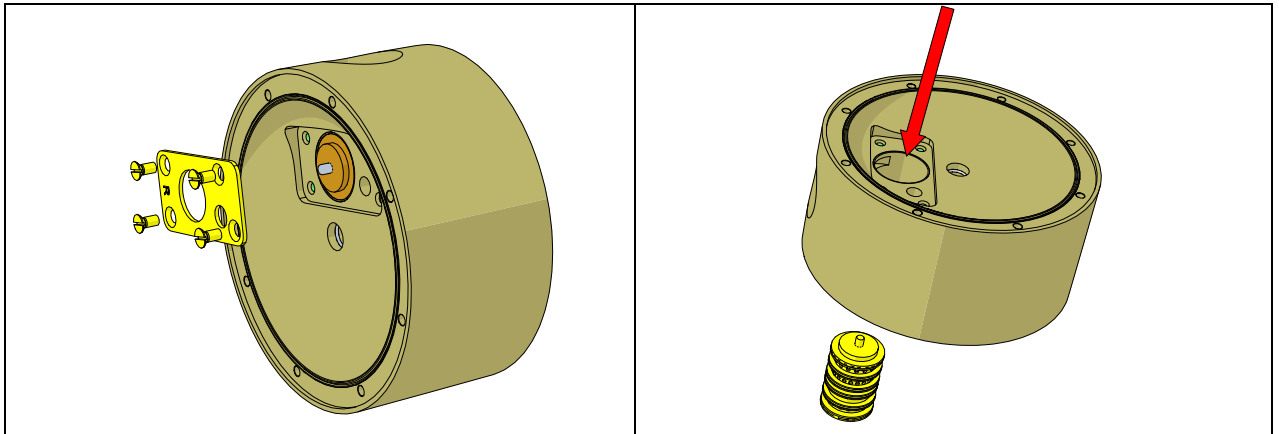

Fig. 3.7.13

Unscrew plate screws [2711] from both sides of the centre body [12] and take out the left and right plate [271].

Fig. 3.7.14

Press out the air valve [61] by means of a pressing device. Be careful not to damage the brass edges of the air valve.

The pump is now completely disassembled. Check all components for wear or damage and replace if necessary.

When air valve is removed from the centre body check the external O-rings (pos. 30) condition and replace if necessary.

3. MAINTENANCE

3.8. T80-T425 – assembly of the pump

The assembly procedure is done in the reverse order to the disassembly.

Nevertheless there are a few things that you have to remember in order to assemble the pump correctly.

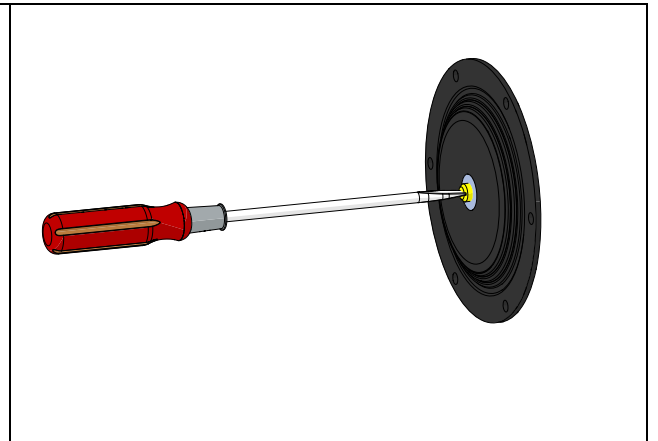
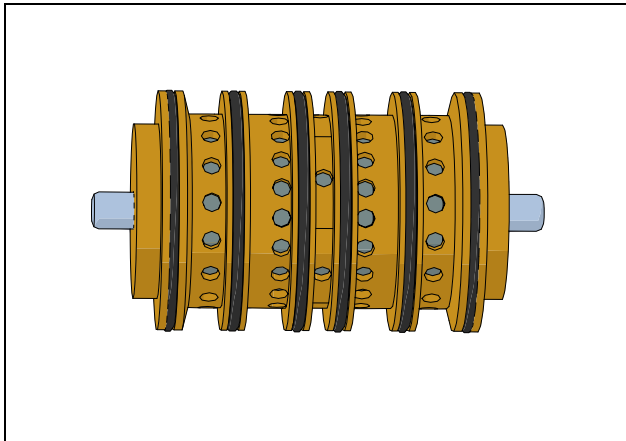

Fig. 3.8.1

When putting the air valve [61] into the centre block [12], apply some water or alcohol on the O-rings to provide smooth insertion of the air valve.

It is recommended to use a pressing device for this operation.

Fig. 3.8.2

When screwing diaphragm grub screw [1652], while screwing it into the diaphragm [15] make sure the grub screw goes all the way.

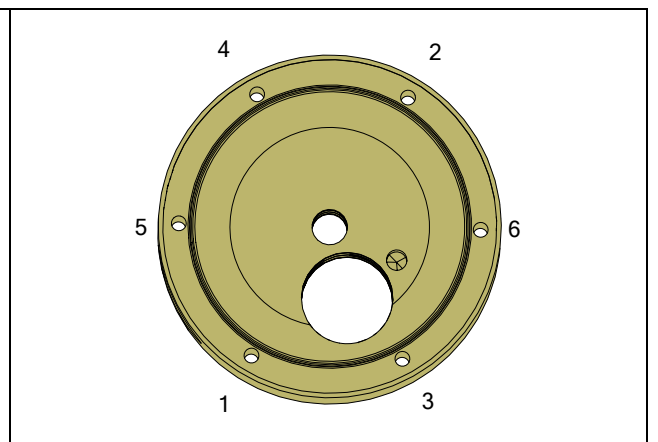
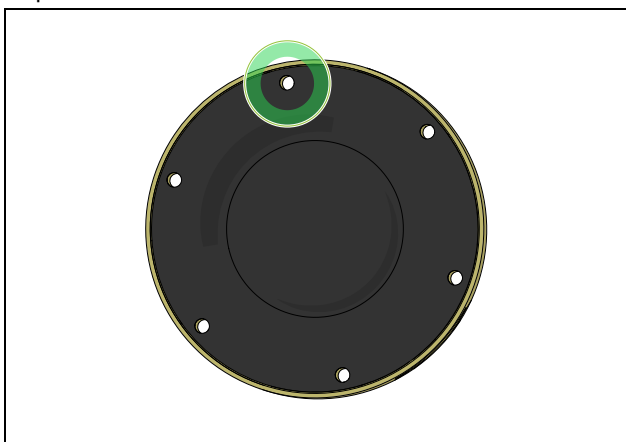

Fig. 3.8.3

During diaphragm [15] assembly, keep both, diaphragm and centerblock [12] holes aligned.

Fig. 3.8.4a

6 stud bolts. When fastening the domed nuts, remember to do it according to the tightening procedure and with the appropriate torque.

3. MAINTENANCE

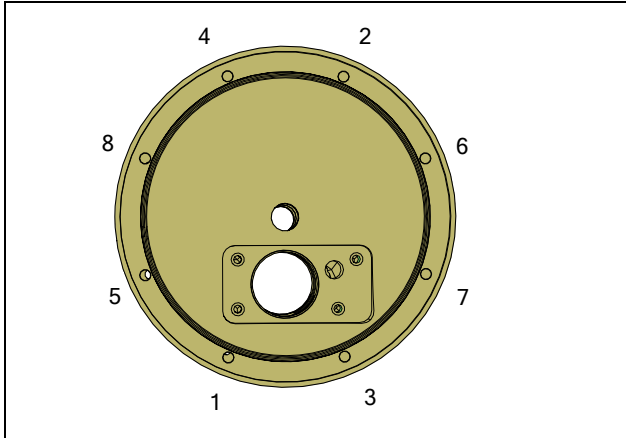

Fig. 3.8.4b

8 stud bolts. When fastening the domed nuts, remember to do it according to the tightening procedure and with the appropriate torque.

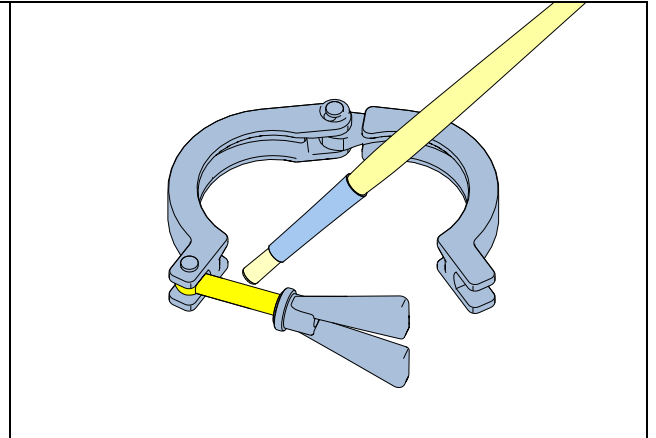

Fig. 3.8.5

When fastening the tri-clamps apply some FDA grade lubricant on the thread.

3.8.1. Test run



We recommend you to conduct a test run of the pump before installing it in the system, so no liquid gets wasted if the pump leaks or perhaps does not start accordingly to wrong assembly of the pump.

After one week of operation retighten the nuts with appropriate torque.

3. MAINTENANCE

3.9. T825 – Disassembly of the pump



The numbers put in brackets, refer to the part numbers in the spare part drawings and spare part lists in chapter 5 "SPARE PARTS".

3.9.1. Before the disassembly procedure

Be sure to drain all liquid from the pump. Cleanse or neutralize the pump thoroughly. Disconnect the air supply and then the suction and discharge connections.

3.9.2. Disassembly procedure

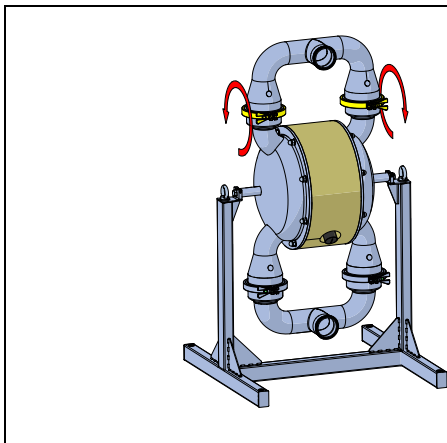

Fig. 3.9.1
Unscrew and remove two tri-clamps [138] connecting the manifold [132] to the housings [11].

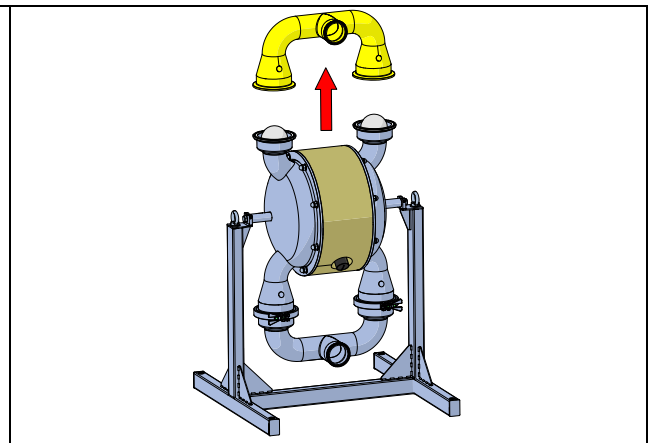

Fig. 3.9.2a
Take off the manifold [132].

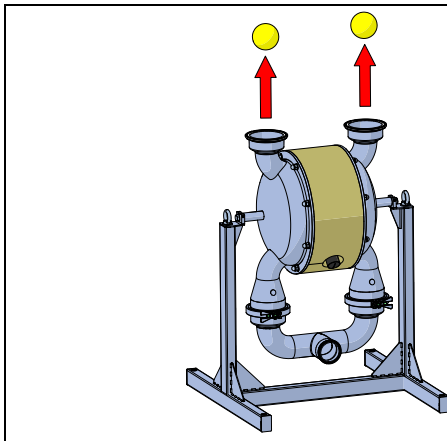

Fig. 3.9.2b
Remove the valve balls [23].

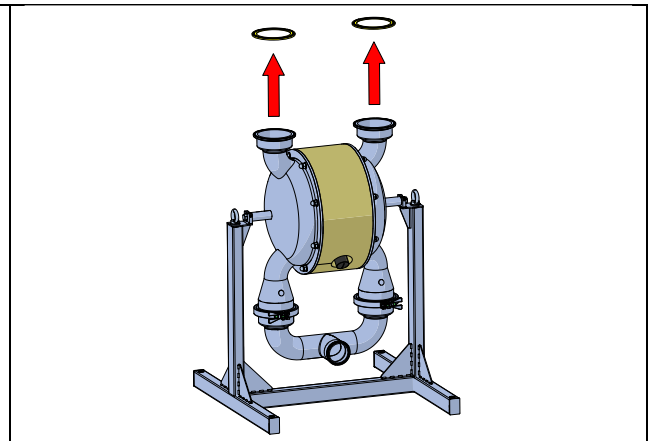

Fig. 3.9.2c
Remove the sealing [18].

3. MAINTENANCE

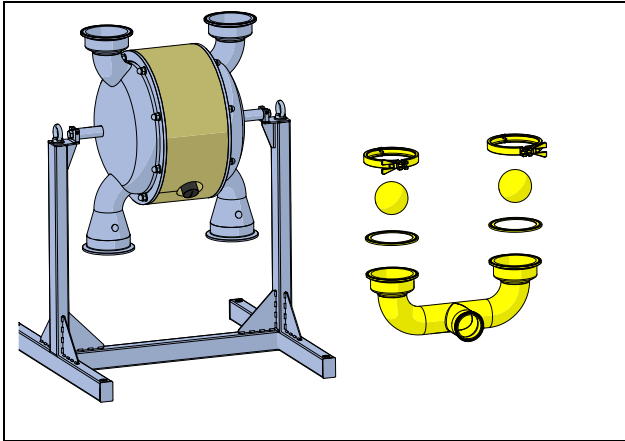

Fig. 3.9.3
Repeat the steps shown in the figures 3.9.1 and 3.9.2 **a, b, c** for suction side.

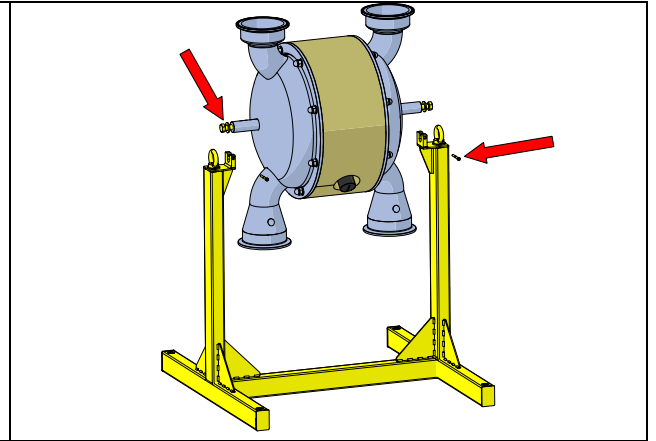

Fig. 3.9.4
Remove the blocking pin [176] and loose the socket head cap screws [174], then take off the pump from the stand [17].

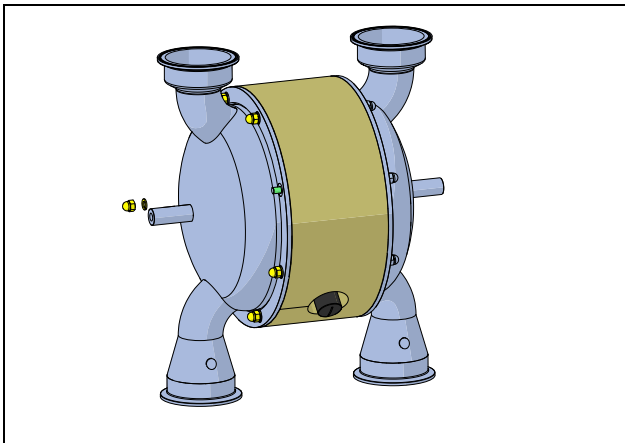

Fig. 3.9.5
Unscrew the domed nuts [37].

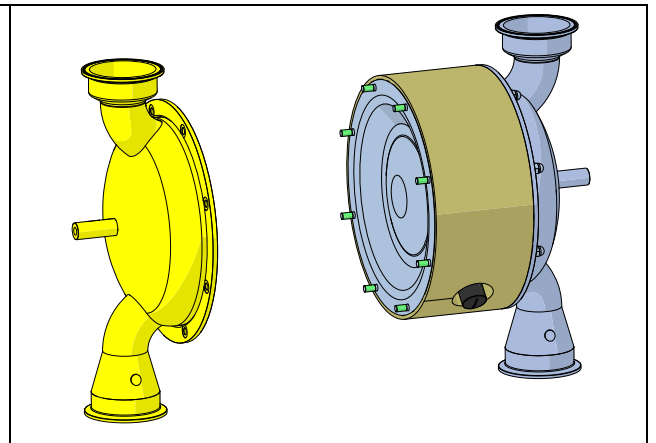

Fig. 3.9.6
Remove the housing [11] from one side of the pump.

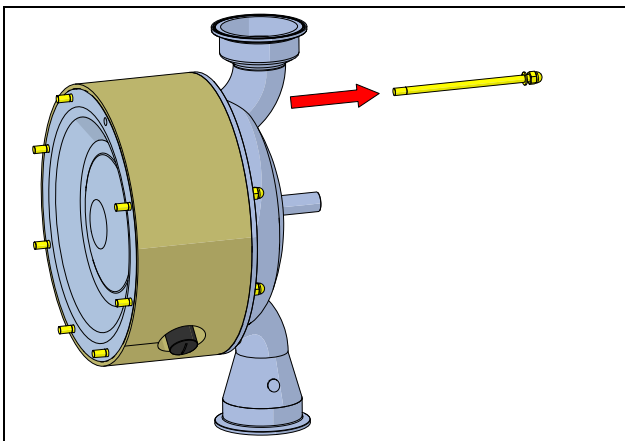

Fig. 3.9.7
Remove the domed nuts [37], stud bolts [14] and washers [38].

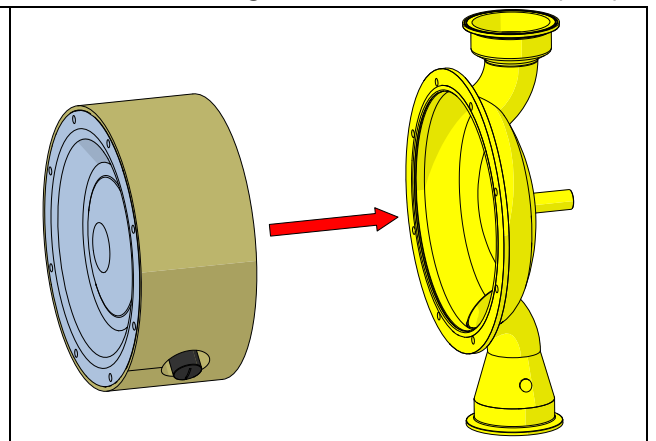

Fig. 3.9.8
Take off the second housing [11].

3. MAINTENANCE

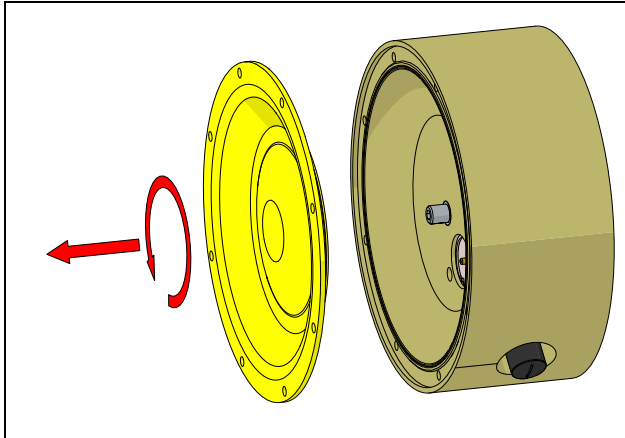

Fig. 3.9.9
Unscrew the diaphragm [15] from one side of the pump.

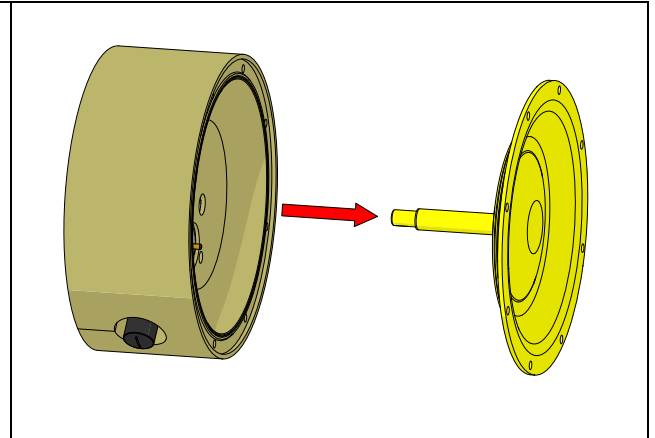

Fig. 3.9.10
Take out the second diaphragm [15] along with the shaft [16].

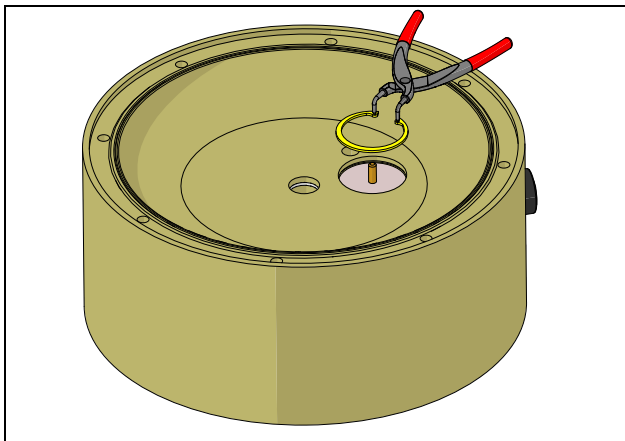

Fig. 3.9.11
Using circlip pliers remove both circlips [27] from the centre block [12].
Attention! While doing this, cover yourself with your other hand, as the circlip easily flips away.

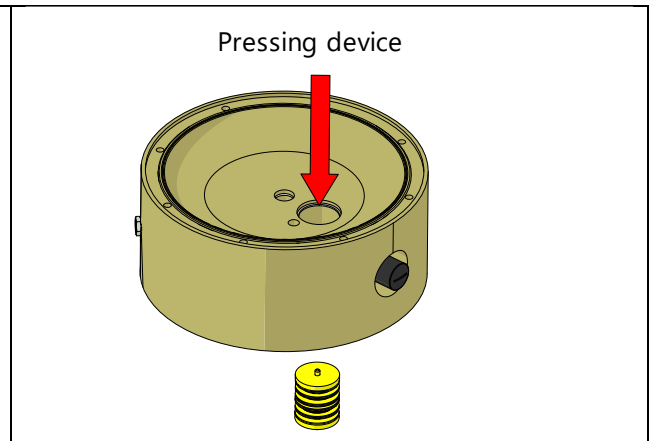

Fig. 3.9.12
Press out the air valve [61] by means of a pressing device. Be careful not to damage edges of the air valve.

The pump is now completely disassembled. Check all components for wear or damage and replace if necessary.

When air valve is removed from the centre body check the external O-rings (pos. 30) condition and replace if necessary.

3. MAINTENANCE

3.10. T825 – assembly of the pump

The assembly procedure is done in the reverse order to the disassembly.

Nevertheless there are a few things that you have to remember in order to assemble the pump correctly.

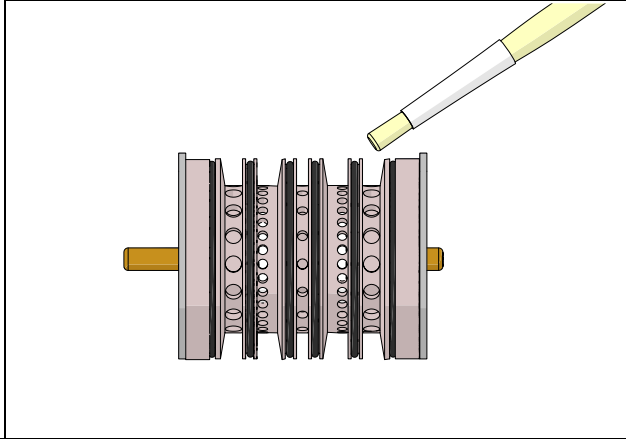

Fig. 3.10.1

When putting the air valve [61] into the centre block [12], apply some water or alcohol on the O-rings to provide smooth insertion of the air valve.

It is recommended to use a pressing device for this operation.

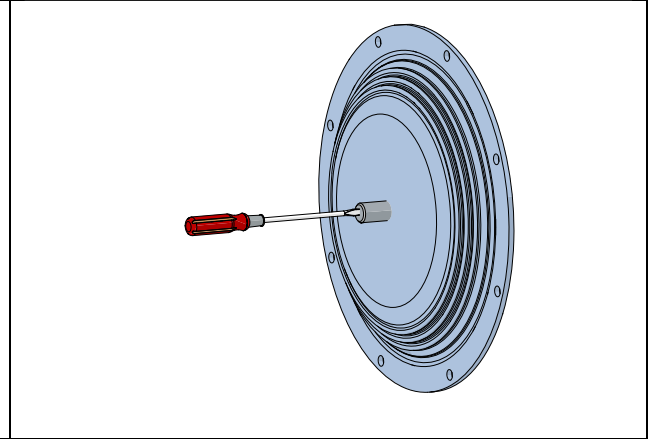

Fig. 3.10.2

While screwing diaphragm grub screw [1652] into the diaphragm [15] make sure it goes all the way.

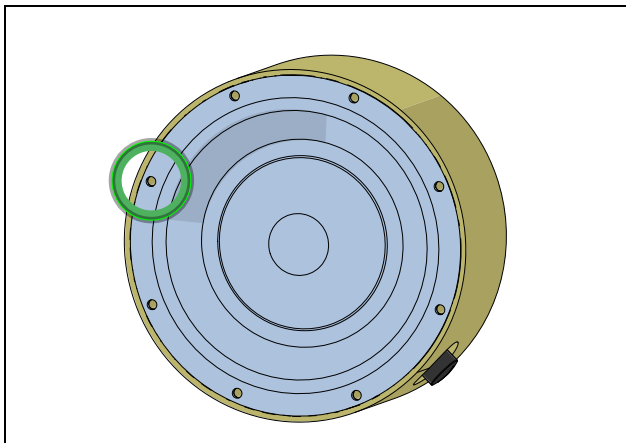

Fig. 3.10.3

When screwing in the diaphragms [15] on the shaft [16], the holes in the diaphragms must align with the holes in the centre block [12].

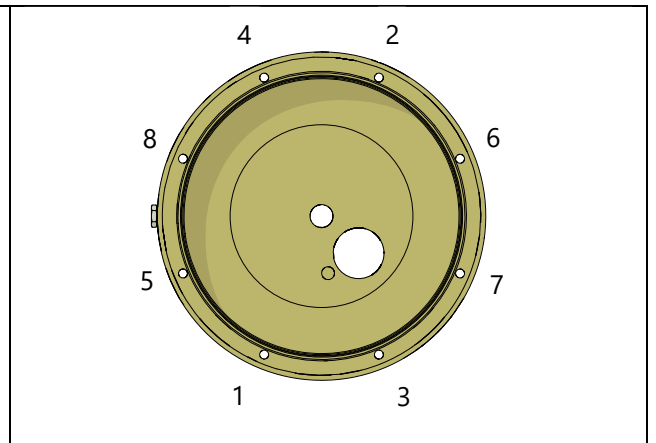

Fig. 3.10.4a

8 stud bolts. When fastening the domed nuts, remember to do it according to the tightening procedure and with the appropriate torque.

3. MAINTENANCE

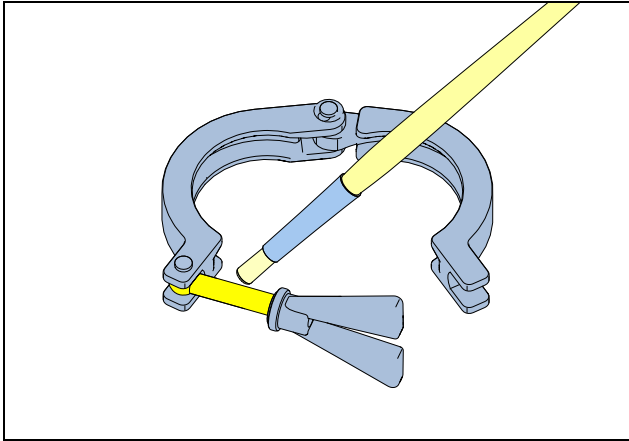

Fig. 3.10.4b

When fastening the tri-clamps apply some FDA grade lubricant on the thread.

3.10.1. Test run



We recommend you to conduct a test run of the pump before installing it in the system, so no liquid gets wasted if the pump leaks or perhaps does not start accordingly to wrong assembly of the pump.

After one week of operation retighten the nuts with appropriate torque.

4. OPTIONS

4. OPTIONS

4.1. Valve options

In pump sizes T80 - T425 flap valves and heavy duty ball cup valves are available as an option to standard ball valves. What is more, T825 pump size can also be configured with flap valves.

4.1.1. Flap valves

It is a great option when the product we intend to pump contains big solids or solids that can be damaged by valve balls (e.g. fruits).

Flap valves made in AISI 316 are mounted in special flap valve cup with clamps between housing and manifold. Pump with flap valves differ from standard pump by valve type, manifolds (pos. 131, 132) and pump housing (pos.11).

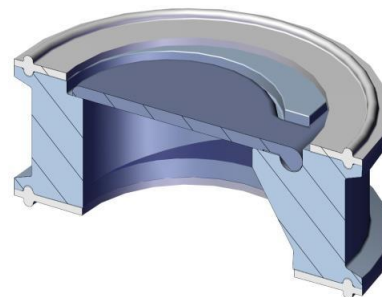

IMPORTANT!

Flap valves are not appropriate for pumping water-like products. If a liquid has low viscosity, the valve will open and close very fast with no shock absorption that is provided by products with particles. Also dry running of the pump for longer periods will cause rapid valve wear and eventually pump stopping.

Flap valves are also not recommended for highly viscous liquids. The flap itself has a small mass compared to a valve ball and might have a problem to overcome the viscous liquid column in order to close properly on the seat.

For spare parts see chapter 5. *Spare parts*.

4. OPTIONS

4.1.2. Ball cup valves

This option is a perfect solution when there is risk of damage to the valve seats from the product. If such situation is to occur there is no need to replace the whole manifolds or housings, just the valve cup what drastically reduces the spare parts cost. Just like the flap valve it is made of AISI 316L stainless steel and is mounted between the housing and manifold with clamps. In the same way the manifolds (pos.131 and 132), pump housing (pos.11) and pump stand (pos. 17) has to be changed in comparison to a standard sanitary pump.

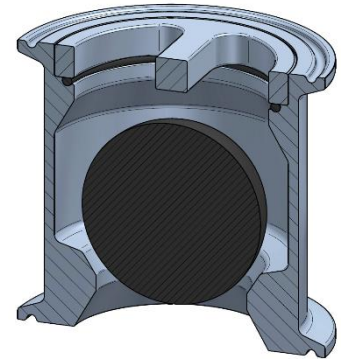

For spare parts see chapter 5. *Spare parts.*

4.2. Heating jacket

The heating jacket is a great option when the pumped product tends to solidify at lower temperatures e.g. chocolate or paraffin. When the pump has finished its duty and is left for some time without operation the product can solidify inside. This is when the heating jacket comes in. Before next pump start-up heating medium like water or steam is into the heating system for a defined period of time to melt the product inside the pump. Only then can the pump be started again with no risk of damage.

Recommendations:

- When using steam as the heating agent the flow must be from top to bottom (due to steam condensation). In case of hot water or other liquid it is the other way around.
- Do not exceed **2 bar** pressure in the heating jacket.



For spare parts see chapter 5. *Spare parts.*

4. OPTIONS

4.3. Magnetic ball lifters

New magnetic ball lifters have been implemented in pump sizes T80 - T225. They are implemented to enable pump emptying when no other draining option is available. Rotating the pump is no longer needed.

The balls are lifted by simply attaching the magnets to the pumps manifold.

Valve balls are available in AISI 420 magnetic stainless steel or PTFE with steel core.

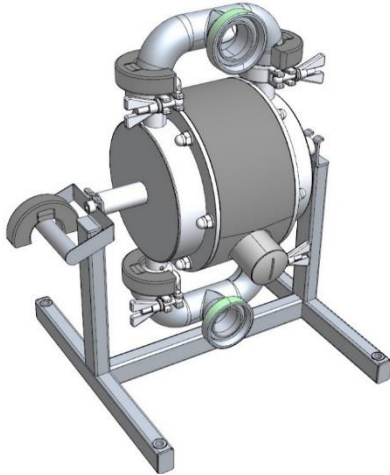

Additional / different parts:

Art. no	Q-ty	Description
6-xxx-23-15	4	Valve ball – PTFE/steel core
6-xxx-23-59	4	Valve ball - AISI420
6-xxx-95M	4	Magnetic ball lifter
6-xxx-170	1	Magnet holder

Pump emptying procedure:

- Install the magnets on the pump manifolds in the area of the valve seat.
- Run the pump slowly.
- After a few cycles the pump will start to run dry.
- Turn off the pump.
- Take off the magnets off the manifolds.

CIP and SIP cleaning procedure recommendation:

During cleaning procedures do not use magnetic ball lifters. When the ball is pulled by the lifter and facing the manifold wall it may trap some liquid to stay inside.

NOTE! Remember to run the pump slowly during cleaning procedures to ensure the diaphragms are balanced on air and liquid side.

NOTE!

The ball lifting system is built with high intensity NdFeB magnets therefore all pacemaker carriers must not approach the ball lifting system components! Intense magnetic field can disturb heart pace. What is more, all devices that can be damaged due to intense magnetic field must not be placed in the vicinity of the ball lifters.



It is important not to join the magnets as it might be difficult to separate them from each other. Furthermore, the magnets are fragile and when connected can crumble.

5. SPARE PARTS

5. SPARE PARTS

5.1. T30 – Spare parts drawing

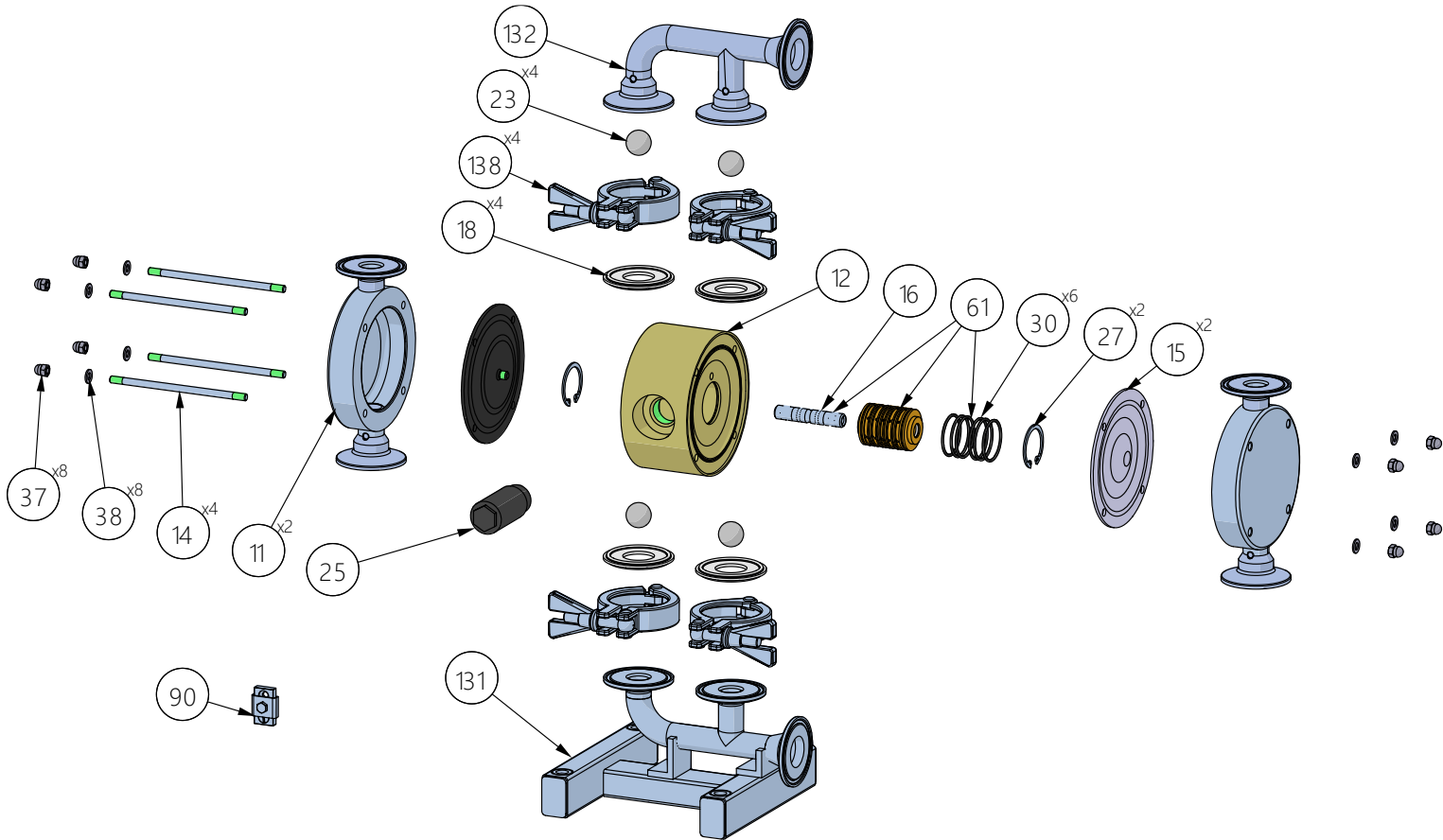

5. SPARE PARTS

5.2. T30 – Spare parts list

Pos.	Q-ty	Description	Material	KIT LIQ	KIT AIR
11	2	Housing	AISI 316L		
12	1	Centre block	PP, Conductive PP		
131	1	Manifold inlet and stand	AISI 316L		
132	1	Manifold outlet	AISI 316L		
138	4	3-clamp	AISI 304		
14	4	Stud bolt	A4-80		
15	2	Diaphragm	EPDM, PTFE, NBR, PTFE/White EPDM, white EPDM	X	
16	1	Diaphragm shaft	AISI 316L		
18	4	Sealing	EPDM, PTFE	X	X
23	4	Valve ball	PTFE, AISI 316, EPDM, NBR, PU	X	
25	1	Muffler	PP		X
27	2	Circlip	Cr3 coated steel		
30	6	O-ring	NBR, FKM, EPDM		
37	8	Stud bolt nut	A4-70		
38	8	Stud bolt washer	A4-70		
61	1	Air valve complete	AISI 316L/FKM, Brass/NBR, Brass/EPDM, AISI 316L/FKM, PET/FKM		X
90	1	Earthing (complete)	AISI 316L / A4-70		

5. SPARE PARTS

5.3. T80-T125 – Spare parts drawing

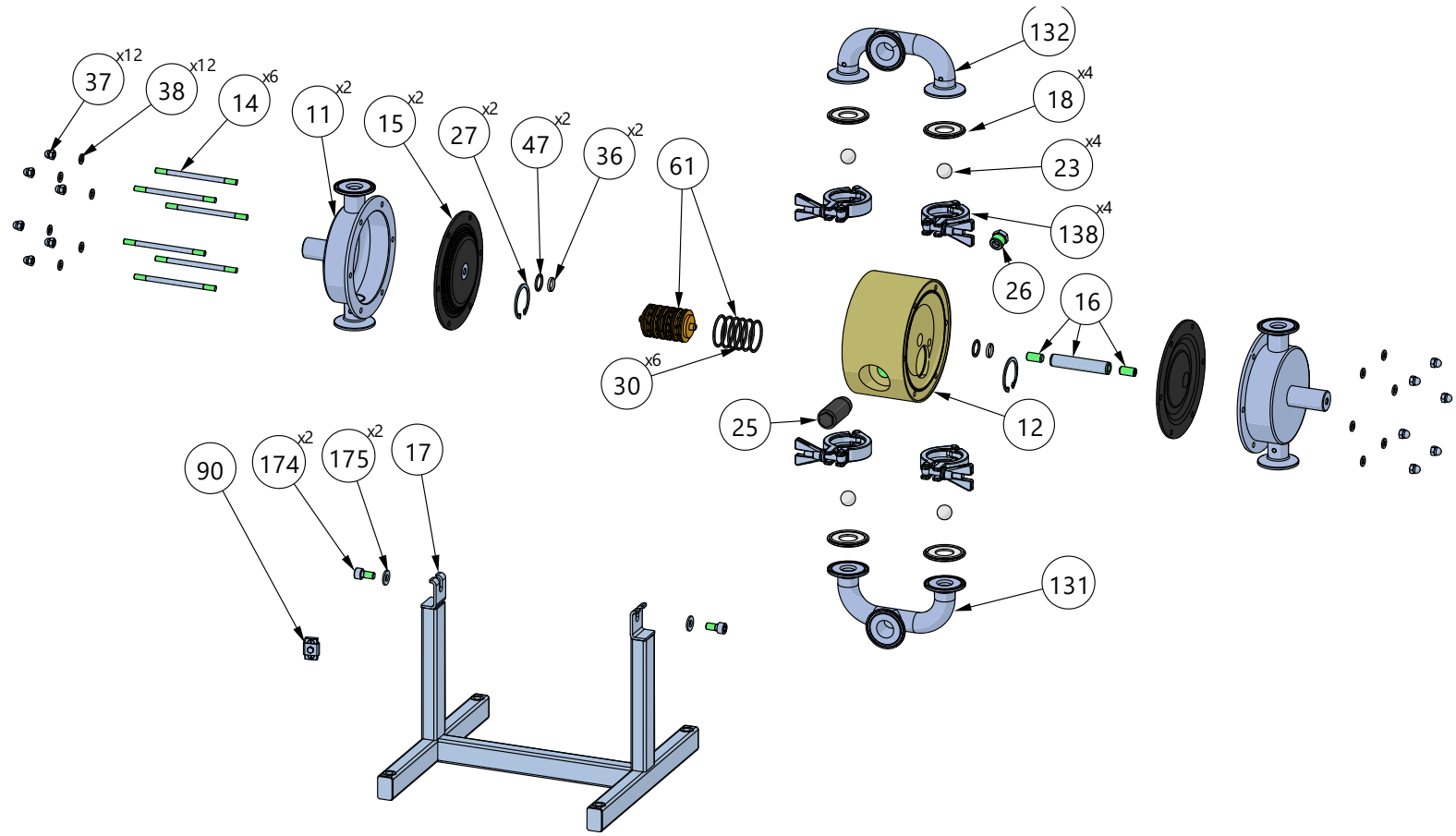

5. SPARE PARTS

5.4. T80-T125 – Spare parts list

Pos.	Q-ty	Description	Material	KIT LIQ	KIT AIR
11	2	Housing	AISI 316L		
12	1	Centre block	PP, PP Conductive		
131	1	Manifold inlet	AISI 316L		
132	1	Manifold outlet	AISI 316L		
138	4	3-clamp	AISI 304		
14	6	Stud bolt	A4-80		
15	2	Diaphragm	EPDM, PTFE, NBR, PTFE/White EPDM, white EPDM	X	
16	1	Diaphragm shaft	AISI 304L		X
17	1	Support	AISI 304L		
174	2	Socket head cap screw	A4-70		
175	2	Washer	A4-70		
18	4	Sealing	EPDM, PTFE	X	X
23	4	Valve ball	PTFE, PTFE 1635, AISI 316, EPDM, NBR, PU	X	
25	1	Muffler	PP		X
26	1	Air intake adapter	Brass		
27	2	Circlip	Cr3 coated steel		
30	6	O-ring	NBR, FKM, EPDM		
36	2	Centre block seal	PE		X
37	12	Stud bolt nut	A4-70		
38	12	Stud bolt washer	A4-70		
47	2/4*	O-ring (back up for 36)	NBR		X
61	1	Air valve complete	AISI 316L/FKM, Brass/NBR (std), Brass/EPDM, AISI 316L/FKM, PET/FKM		X
90	1	Earthing (complete)	AISI 316L / A4-70		

* T125 only

5. SPARE PARTS

5.5. T80 – T125 – Spare parts options

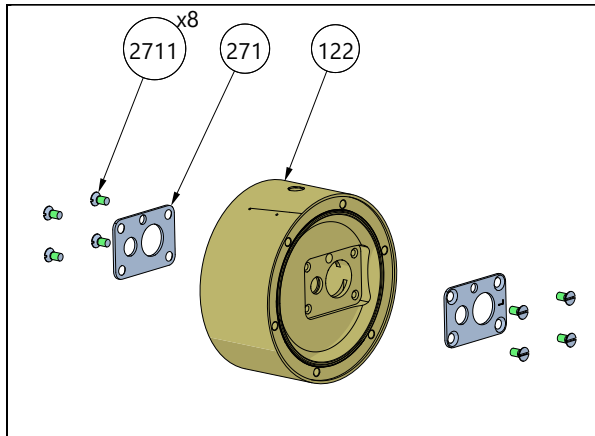

Air valve reinforcement 5TS (T125 only) – std on TX125			
122	1	Center block	PP, PP Cond.
271	1	Set of 2 reinforcement plates	AISI 316L
2711	8	Screws	A4-70

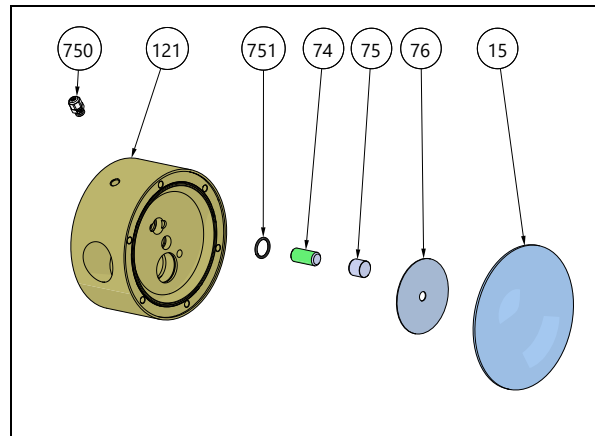

Diaphragm stroke sensor 5C			
121	1	Centerblock for stroke sensor	PP
751	1	O-ring	NBR, FKM, EPDM
74	1	Inductive sensor	CuZn
75	1	Sensor cap	PP
76	1	Sensing plate	AISI 316L
750	1	Cable gland	PP

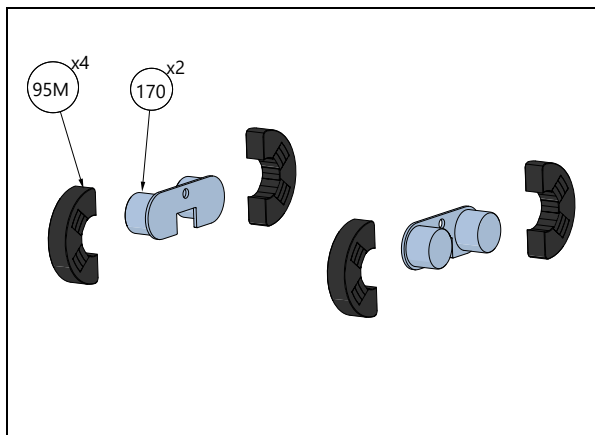

Magnetic ball lifters 5ML			
23-15	4	Valve ball	PTFE/SS core
23-59	4	Valve ball	AISI420
95M	4	Magnetic ball lifter	PE1000
170	2	Holder	AISI316L

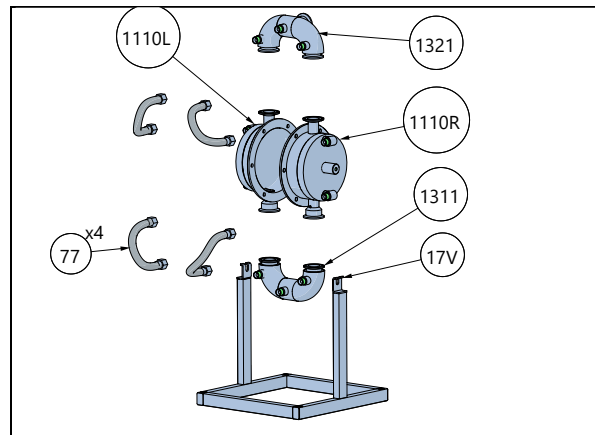

Heating jacket J			
1110L	1	Housing (left)	AISI316L
1110R	1	Housing (right)	AISI316L
1311	1	Inlet manifold	AISI316L
1321	1	Outlet manifold	AISI316L
17V	1	Stand	AISI304
77	4	Hose	AISI316Ti/304

5. SPARE PARTS

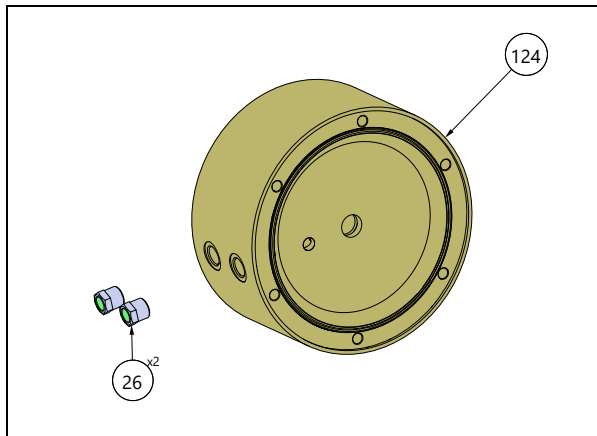

External air supply 5EC			
124	1	Center block	PP, PP Cond.
26	2	Air intake adapter	Brass

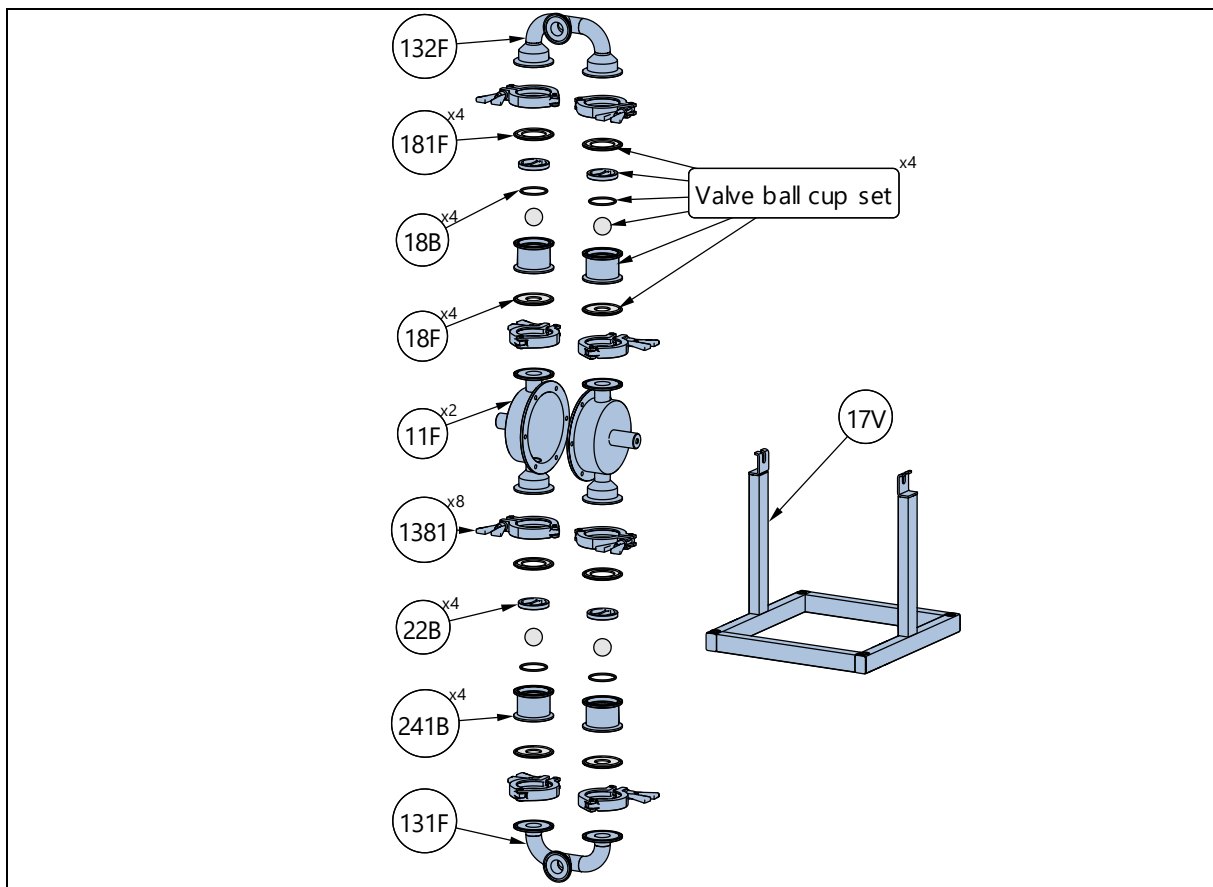

Ball cup valves 5SC			
11F	2	Housing	AISI316L
131F	1	Manifold inlet	AISI316L
132F	1	Manifold outlet	AISI316L
1381	8	Tri-clamp	AISI304
17V	1	Stand	AISI304
18F	4	Sealing	PTFE, EPDM
181F	4	Sealing	PTFE, EPDM
18B	4	Stopper O-ring	FEP/FKM
22B	4	Valve ball stopper	AISI316L
241B	4	Ball valve cup	AISI316L
6-125-24B-x-SET *	4	Valve ball cup set	

x - valve ball material.

5. SPARE PARTS

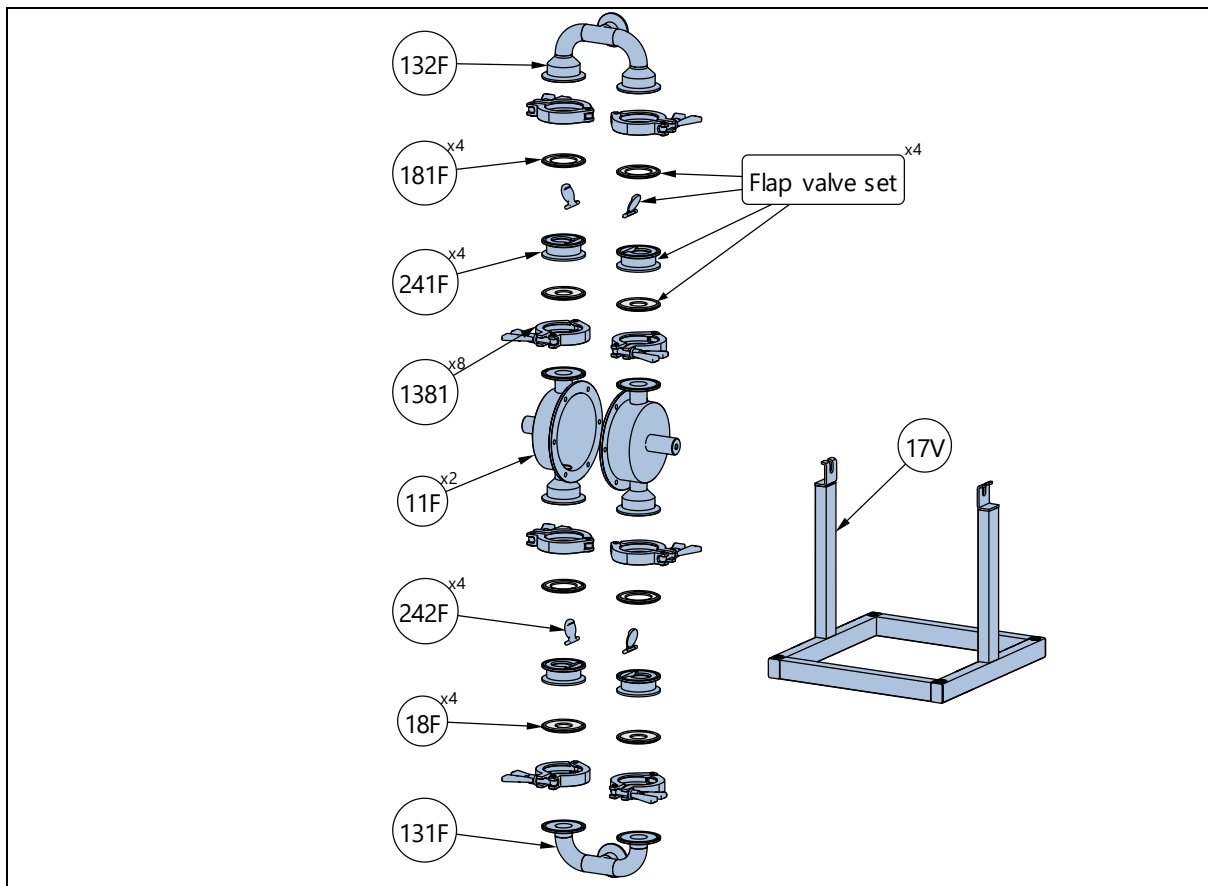

Ball cup valves			
11F	2	Housing	AISI316L
131F	1	Manifold inlet	AISI316L
132F	1	Manifold outlet	AISI316L
1381	8	Tri-clamp	AISI304
17V	1	Stand	AISI304
18F	4	Sealing	PTFE, EPDM
181F	4	Sealing	PTFE, EPDM
241F	4	Flap valve seat	AISI 316L
242F	4	Flap	AISI316L
241B	4	Ball valve cup	AISI316L
6-125-24F-SET	4	Flap valve set	-

5. SPARE PARTS

5.6. T225-T425 – Spare parts drawing

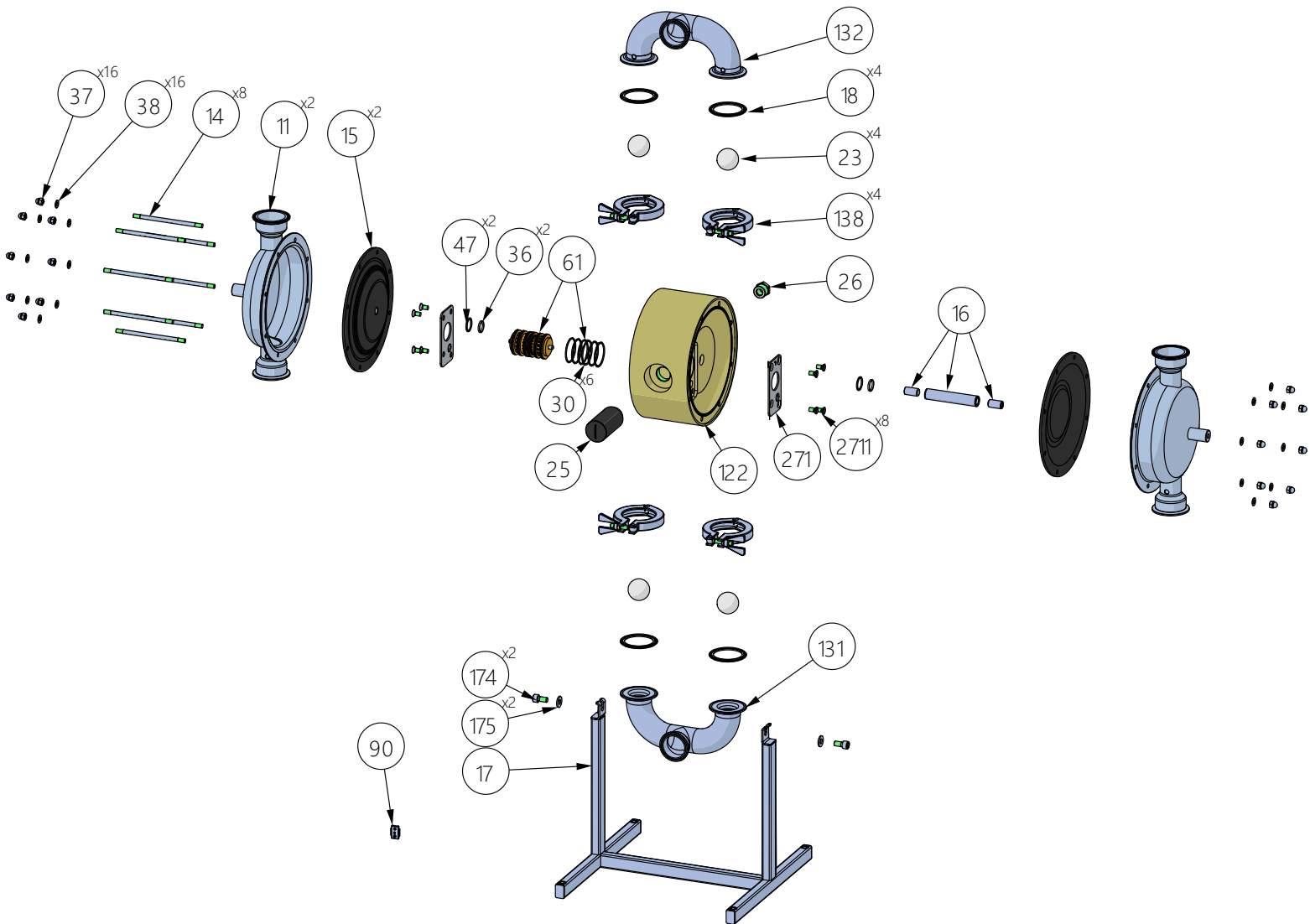

5. SPARE PARTS

5.7. T225-T425 – Spare parts list

Pos.	Q-ty	Description	Material	KIT LIQ	KIT AIR
11	2	Housing	AISI 316L		
122	1	Centre block	PP, PP Conductive		
131	1	Manifold inlet	AISI 316L		
132	1	Manifold outlet	AISI 316L		
138	4	3-clamp	AISI 304		
14	8	Stud bolt	A4-80		
15	2	Diaphragm	EPDM, PTFE, NBR, PTFE/White EPDM, white EPDM	x	
16	1	Diaphragm shaft complete	AISI 304L		x
17	1	Support	AISI 304L		
174	2	Socket head cap screw	A4-70		
175	2	Washer	A4-70		
18	4	Sealing	EPDM, PTFE	x	x
23	4	Valve ball	PTFE, PTFE 1635, AISI 316, EPDM, NBR, Polyurethane	x	
25	1	Muffler	PP		x
26	1	Air intake adapter	Brass		
271	1	Set 2 plates (left and right)	AISI 316L		
2711	8	Screw	AISI 316		
30	6	O-ring	NBR, FKM, EPDM		
36	2	Centre block seal	PE		x
37	16	Stud bolt nut	A4-70		
38	16	Stud bolt washer	A4-70		
47	2	O-ring (back up for 36)	NBR		x
61	1	Air valve complete	AISI 316/FKM, Brass/NBR (std) PET/FKM, Brass/EPDM, AISI 316/FKM		x
90	1	Earthing (complete)	AISI 316L / A4-70		

5. SPARE PARTS

5.8. T225 – T425 – Spare parts options

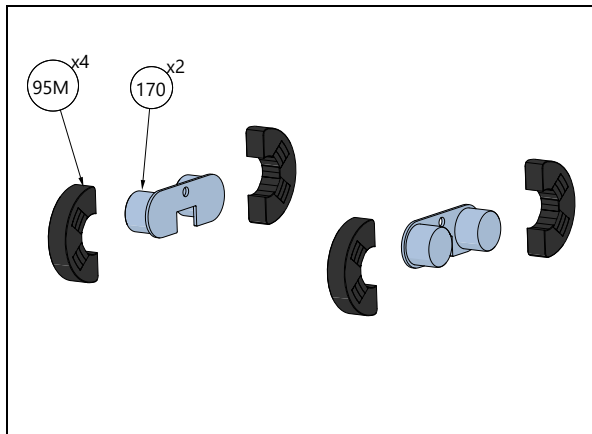

Magnetic ball lifters 5ML			
23-15	4	Valve ball	PTFE/SS core
23-59	4	Valve ball	AISI420
95M	4	Magnetic ball lifter	PE1000
170	2	Holder	AISI316L

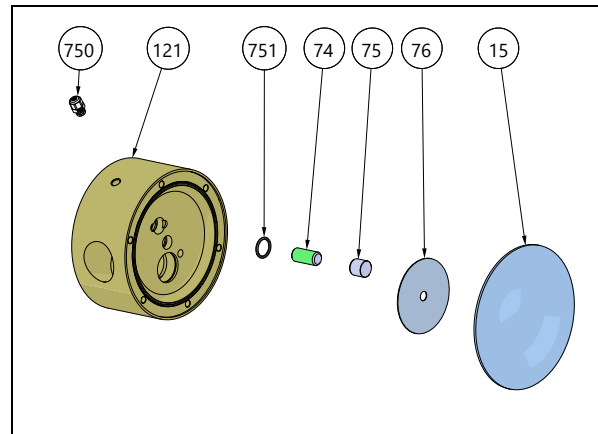

Diaphragm stroke sensor 5C			
121	1	Centerblock for stroke sensor	PP
751	1	O-ring	NBR, FKM, EPDM
74	1	Inductive sensor	CuZn
75	1	Sensor cap	PP
76	1	Sensing plate	AISI 316L
750	1	Cable gland	PP

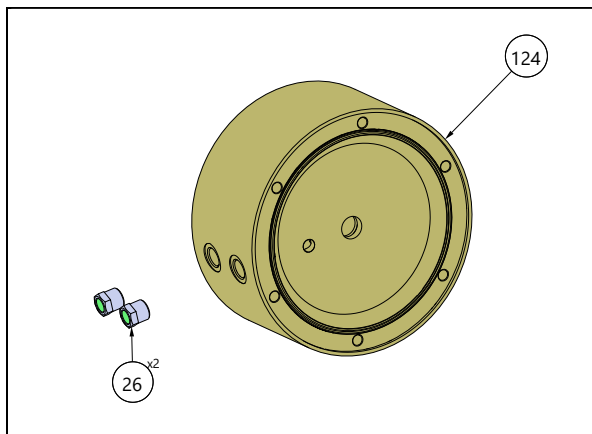

External air supply 5EC			
124	1	Center block	PP, PP Cond.
26	2	Air intake adapter	Brass

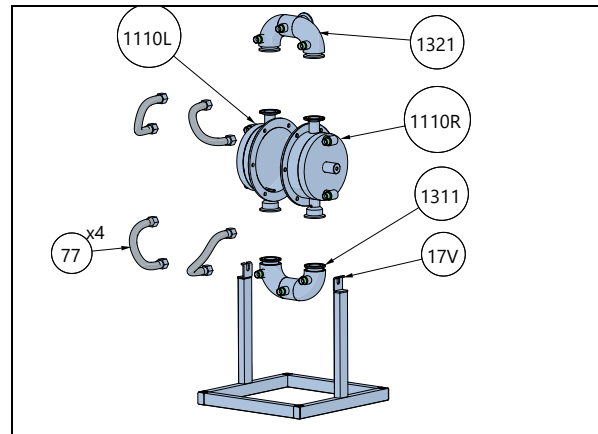

Heating jacket J			
1110L	1	Housing (left)	AISI316L
1110R	1	Housing (right)	AISI316L
1311	1	Inlet manifold	AISI316L
1321	1	Outlet manifold	AISI316L
17V	1	Stand	AISI304
77	4	Hose	AISI316Ti/304

5. SPARE PARTS

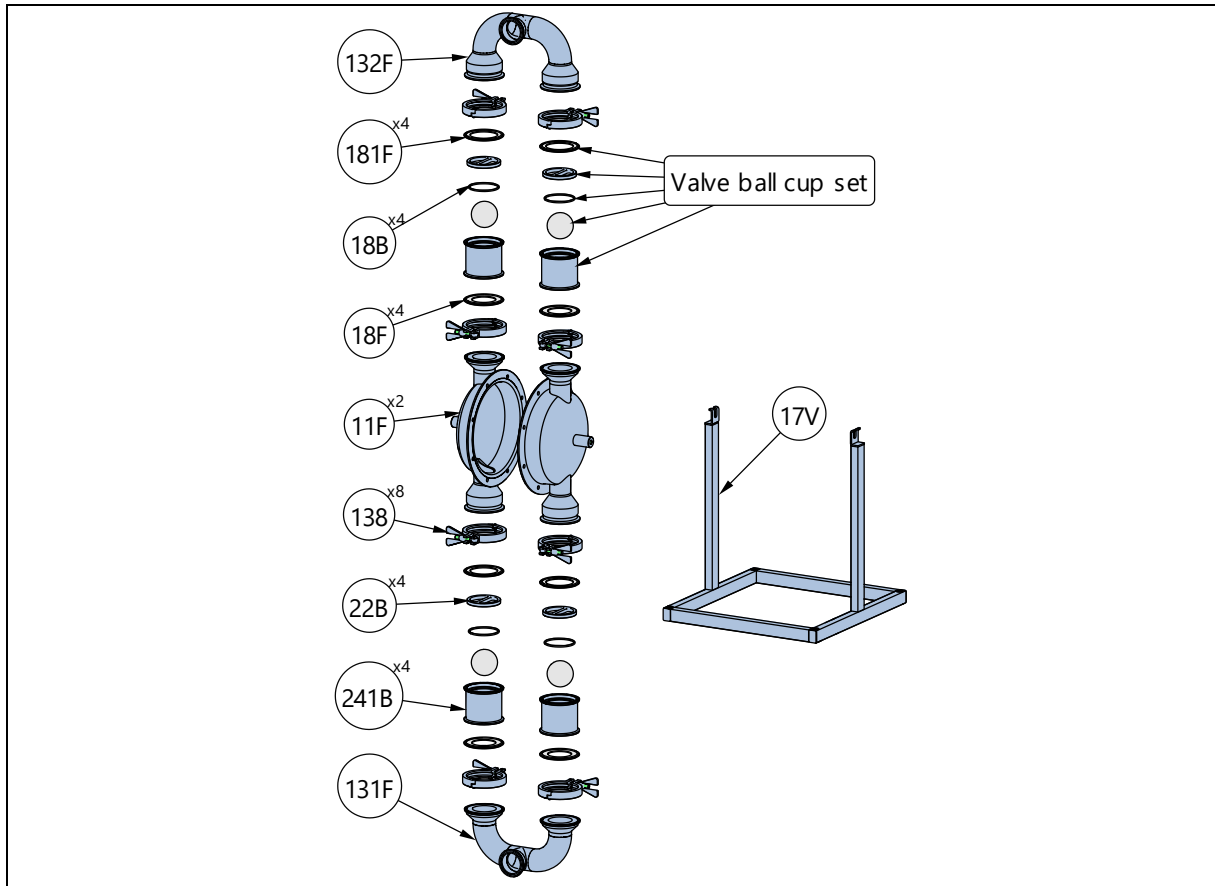

Ball cup valves 5SC			
11F	2	Housing	AISI316L
131C	2	Inlet manifold	AISI316L
138	8	Tri-clamp	AISI304
17V	1	Stand	AISI304
18F	8	Sealing	PTFE, EPDM
182	4	Stopper O-ring	FEP/FKM
22B	4	Valve ball stopper	AISI316L
241B	4	Ball valve cup	AISI316L
6-425-24B-x-SET	4	Ball valve cup set	-

x - valve ball material.

5. SPARE PARTS

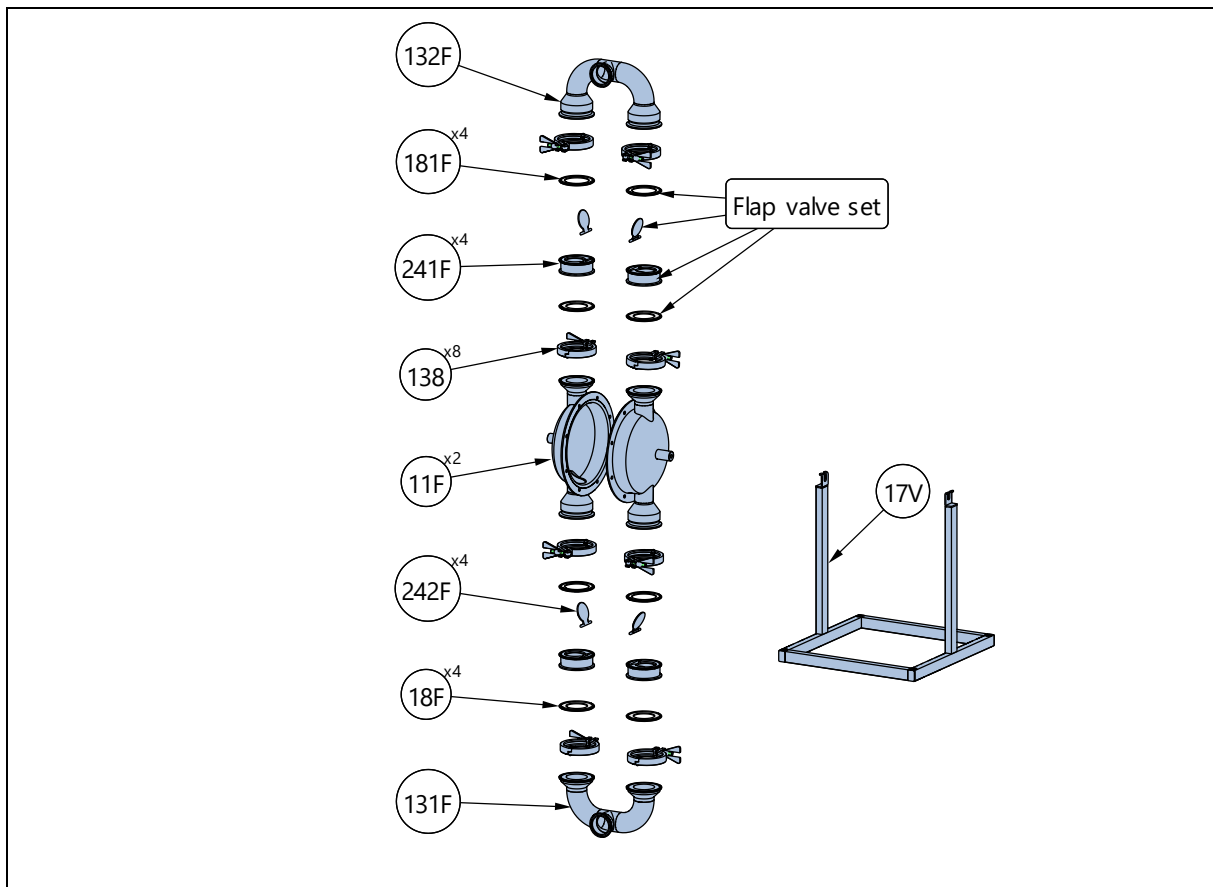

Flap valves			
11F	2	Housing	AISI316L
131F	1	Inlet manifold	AISI316L
132F	1	Outlet manifold	AISI316L
17V	1	Stand	AISI304
181F	4	Sealing	PTFE, EPDM
18F	8	Sealing	PTFE, EPDM
138	8	Tri-clamp	AISI304
241F	4	Flap valve seat	AISI316L
242F	4	Flap	AISI316L
6-425-24F-SET	4	Flap valve set	-

5. SPARE PARTS

5.9. T825 – Spare parts drawing

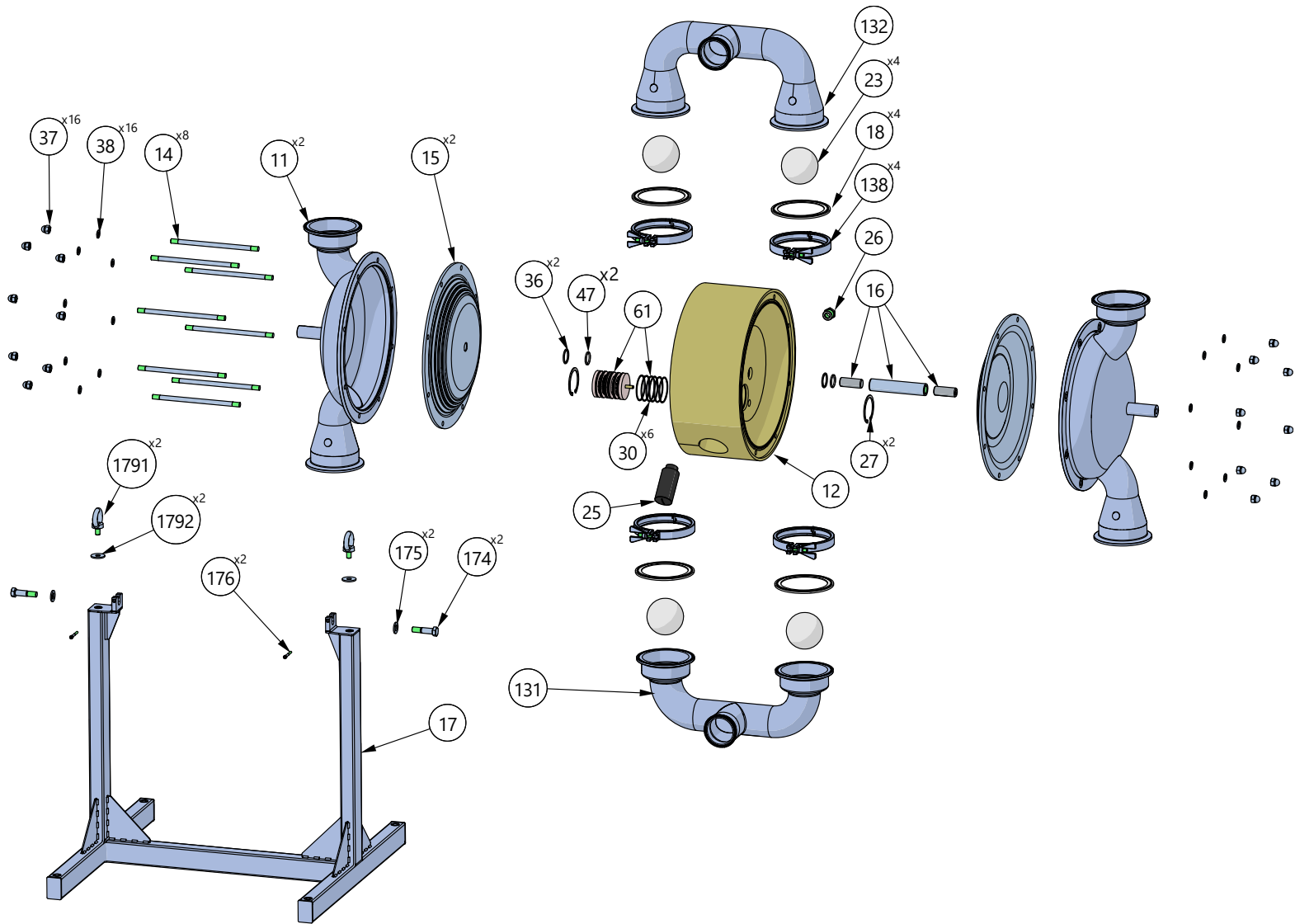

5. SPARE PARTS

5.10. T825 – Spare parts list

Pos.	Q-ty	Description	Material
11	2	Housing	AISI 316L
12	1	Centre block	PP, PE1000 conductive
131	1	Manifold inlet	AISI 316L
132	1	Manifold outlet	AISI 316L
138	4	3-clamp	AISI 304
14	8	Stud bolt	A4-80
15	2	Diaphragm	EPDM, PTFE, NBR
16	1	Shaft set	AISI 304L
17	1	Stand	AISI 304
174	2	Socket head cap screw	A2-70
175	2	Socket head cup screw washer	A4-70
176	2	Blocking pin	AISI316L
1791	2	Eye bolt	A2-70
1792	2	Eye bolt washer	A2-70
18	4	Sealing	PTFE
23	4	Valve ball	PTFE, EPDM
25	1	Muffler	PP
26	1	Air intake adapter	Brass
27	2	Circlip	Cr3 coated steel
30	6	O-ring	NBR, FKM, EPDM
36	2	Centre block seal	PE
37	16	Stud bolt nut	A4-70
371	32	Manifold screw nut	A4-70
38	16	Stud bolt washer	A4-80
47	2	O-ring (back up for 36)	NBR
61	1	Air valve complete	PET/NBR (standard); AISI 316/FKM, Brass/NBR, Brass/EPDM, AISI 316/FKM, PET/FKM

5. SPARE PARTS

5.11. T825 – Spare parts options

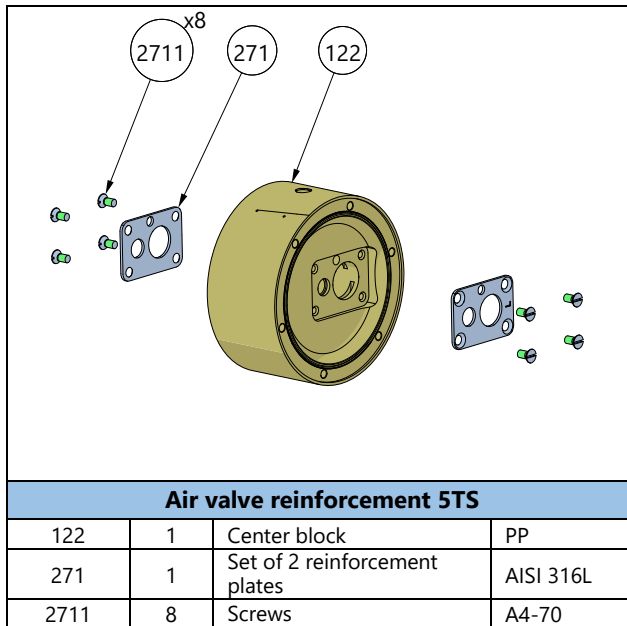

Air valve reinforcement 5TS			
122	1	Center block	PP
271	1	Set of 2 reinforcement plates	AISI 316L
2711	8	Screws	A4-70

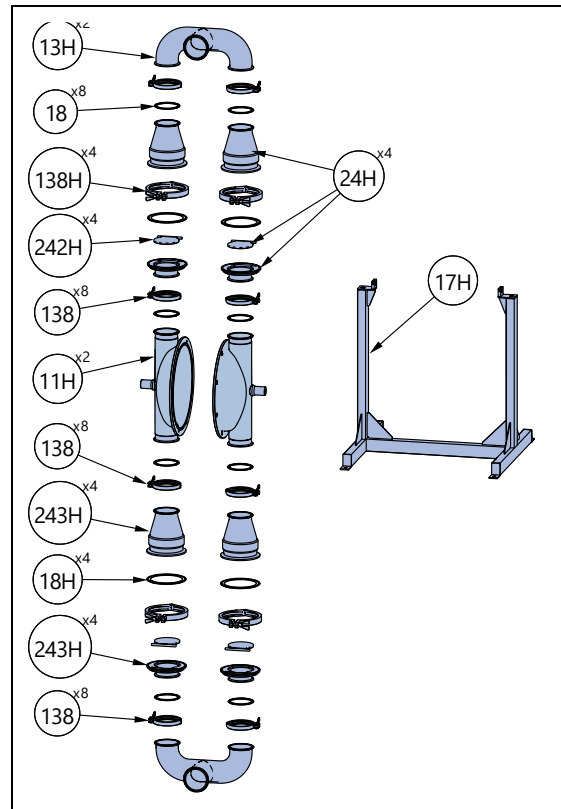

Flap valves			
11H	2	Housing	AISI316L
13H	2	In/outlet manifold	AISI316L
138	8	Tri-clamp (DN100)	AISI304L
138H	4	Tri-clamp (DN150)	AISI304L
17H	1	Stand	AISI304L
18	8	Sealing (DN100)	PTFE
18H	4	Sealing (DN150)	PTFE
241H	4	Flap valve seat	AISI316L
242H	4	Flap	AISI316L
243H	4	Flap valve housing	AISI316L
24H	4	Flap valve complete (241H+242H+243H)	AISI316L

5. SPARE PARTS

5.12. Stocking recommendation

Even at normal operation some details in the pump will be worn. In order to avoid expensive breakdowns we recommend having a few spare parts in stock.

Depending on the severity of the operation and the importance of assuring continuous work we offer two different spare part **KITS** – **KIT LIQ** includes parts on pump wetted side and **KIT AIR** includes parts on the pump air side that are subject to wear.

T30, T80, T125, T225, T425:

	Pos.	Description	Q-ty
KIT LIQ	15	Diaphragm	2
	18	Sealing	4
	23	Valve ball	4

T30:

	Pos.	Description	Q-ty
KIT AIR	18	Sealing	4
	61	Air valve complete	1
	25	Muffler	1

T80, T125, T225, T425:

	Pos.	Description	Q-ty
KIT AIR	18	Sealing	4
	61	Air valve complete	1
	16	Diaphragm shaft	1
	36	Centre block seal	2
	47	O-ring(back up for 36)	2/4*
	25	Muffler	1

* For T125 pump

5.13. How to order parts

When ordering spare parts for Tapflo pumps, please let us know what is the **model number** and **serial number** from the pump centre body. Then just indicate the part numbers from the spare parts list and quantity of each item.

5. SPARE PARTS

5.14. Pump code

The model number on the pump and on the front page of this instruction manual tells the pump size and materials of the pump.

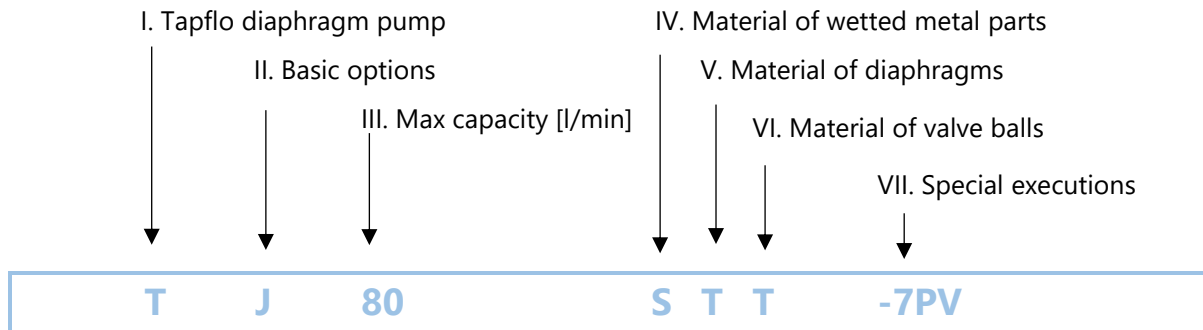

I. T = Tapflo diaphragm pump

II. Basic options:

B = Backup diaphragm pump

C = Leap

D = Drum pump

J = Heating jacket

P = Powder pump

X = ATEX approved, group II, cat. 2

Z = ATEX approved, group II, cat. 1

IV. Material of wetted metal parts:

F = 1.4435 Stainless steel (Bassler norm)

H = Hastelloy

S = stainless steel AISI 316L

V. Material of diaphragms:

E = EPDM

W = White (food grade) EPDM

N = NBR (nitrile rubber)

T = PTFE

Z = PTFE with white back (food grade)

B = PTFE TFM 1705b

VI. Material of valve balls:

E = EPDM

N = NBR (nitrile rubber)

T = PTFE

S = AISI 316 stainless steel

P = PU (polyurethane)

K = Ceramic

B = PTFE TFM 1635

blank = flap valve version

VII. Special executions:

1 = Optional in/outlet

3 = Optional connection type

4 = Backup diaphragm system configuration

5 = Other special executions

6 = Optional material of centre body

7 = Optional material of air valve

8 = Optional material of pos. 18 seals

9 = Optional material of housing stud bolts

14 = Optional pump feet

15 = Flap valve execution

16 = Optional clamp type

6. DATA

6. DATA

6.1. Capacity curves

The performance curves are based on water at 20°C. Other circumstances might change the performance. See below how the capacity will change at different viscosities and suction lifts.

Example:

A flow of 30 litre/minute is desired. The discharge pressure is calculated to 25 mWC. We choose a T80 pump. It requires an air pressure of 4 bar and will consume approximately 0.20 Nm³ of air per minute.

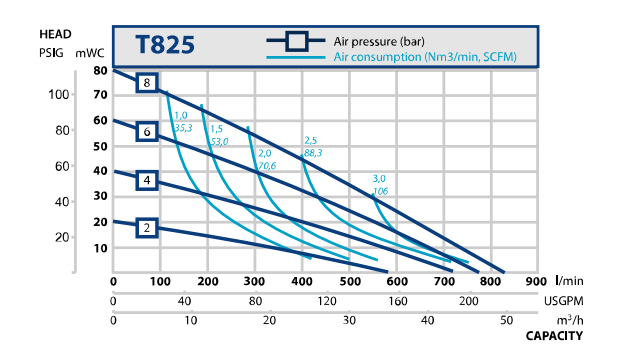
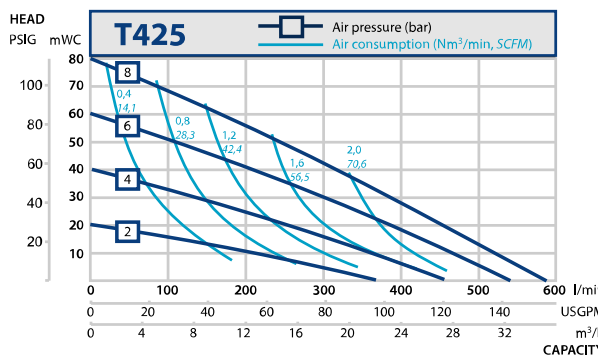
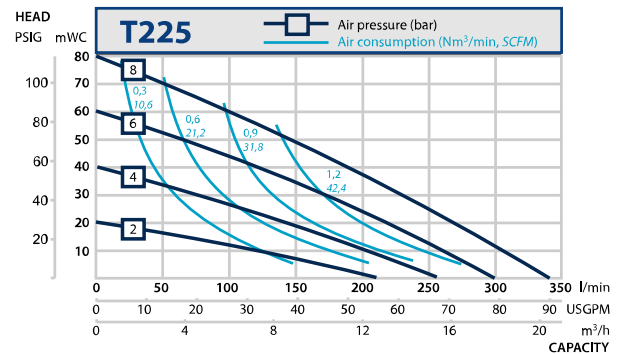
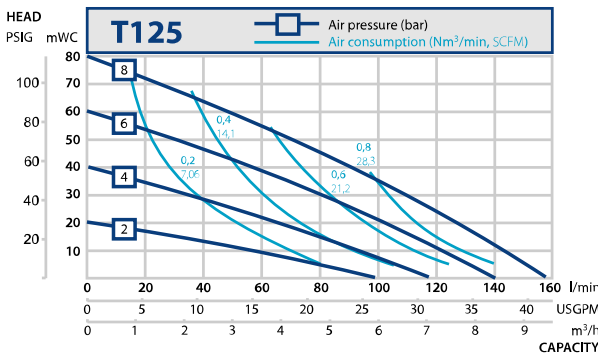
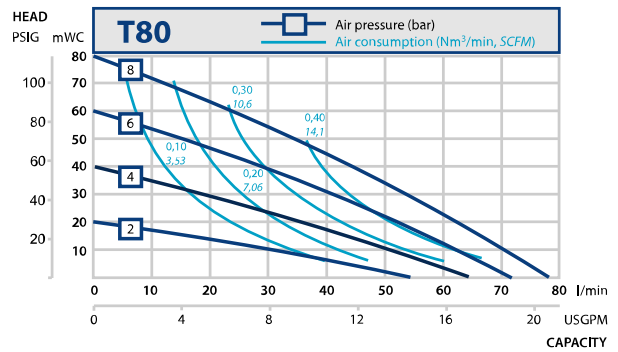
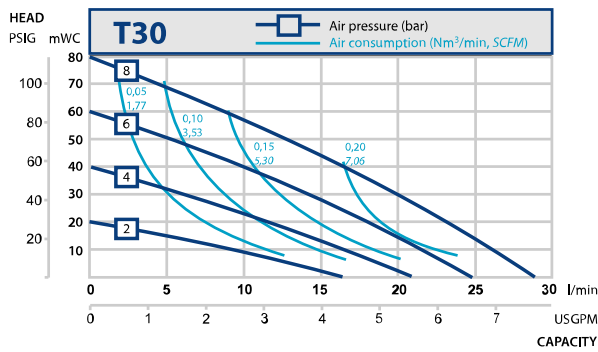

Recommended flow is half of the max flow, e.g. recommended flow for a T80 is 40 l/min.

6. DATA

6.2. Capacity changes

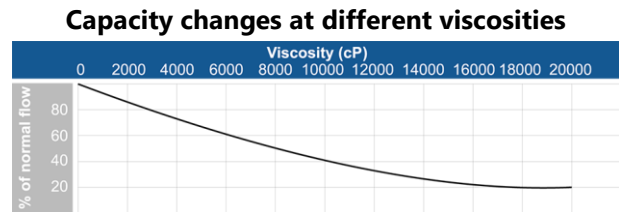
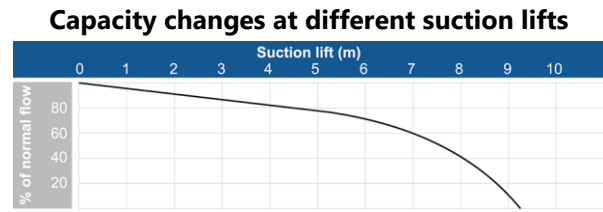

6.3. Dimensions

Dimensions in mm (where other is not indicated)

Dimensions in inch (where other is not indicated)

General dimensions only, ask us for detailed drawings. Changes reserved without notice.

Dimension	PUMP SIZE						
	T30	T80	T125	T225	T425	T825	
A	169	295	320	404	468	750	
	6.7	11.6	12.6	15.9	18.4	29.5	
B	153	303	328	412	476	760	
	6	11.9	12.9	16.2	18.7	29.9	
D	313	393 / 513**	458 / 578**	647 / 792**	808 / 950**	1288 / 1495**	
	12.3	15.5/20.2	18 / 22.7	25.5 / 31.1	31.8 / 37.4	50.7 / 58.8	
E	240	294 / 409**	350 / 488**	528 / 690**	664 / 775**	1034.5 / 1270**	
	9.4	11.6 / 16.1	13.8 / 19.5	20.6 / 27.2	26.1 / 30.5	40.7 / 50	
G	34	10	10	10	10	20	
	1.3	0.4	0.4	0.4	0.4	0.8	
H	30	30	30	30	30	60	
	1.2	1.2	1.2	1.2	1.2	2.4	
I	48	74.5 / 79**	83 / 64**	86.5 / 70**	98.5 / 140**	206.5 / 165**	
	1.9	2.9 / 1.2	3.2 / 2.5	3.4 / 2.8	3.9 / 5.5	8.1 / 6.5	
J	TC ¹	25	25	38	51	70	76.1
	DIN ²	DN20	DN25	DN40	DN50	DN65	DN80
	SMS ³	25	25	38	51	63.5	76.1
	RJT ⁴	1"	1"	1 1/2"	2"	3"	3 1/2"
ØK	9	9	9	9	9	25x13	
	0.4	0.4	0.4	0.4	0.4	1x0.5	
L	G 1/8"	G 1/4"	G 1/4"	G 1/2"	G 1/2"	G 1/2"	
ØM*	50.5	50.5	50.5	64	91	98 / 119**	
	2.0	2.0	2.0	2.5	3.6	3.9 / 4.7	
ØN*	22.6	22.6	35.6	48.6	66.8	72.9 / 100**	
	0.9	0.9	1.4	1.9	2.6	2.9 / 3.9	
X	125	275	300	384	448	710	
	4.9	10.8	11.8	15.1	17.6	28	

* = Dimensions for standard clamp connections only

** = Dimensions with flap valves and heavy duty valve cup version

1 = Clamp connections according to SMS3017 (T30 – T225) / ISO2037 (T425-T825)

2 = Threaded connections according to DIN 11851

3 = Threaded connections according to SMS 1145

4 = Threaded connections according to BS 4825-5

6. DATA

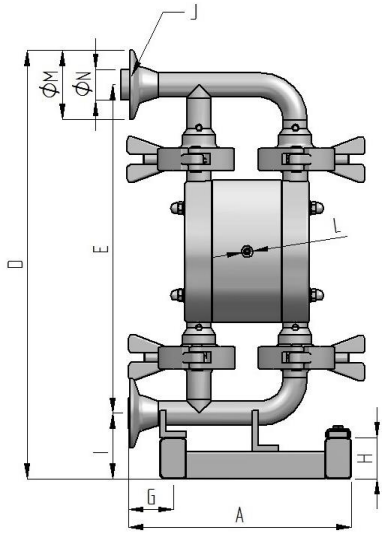

T30

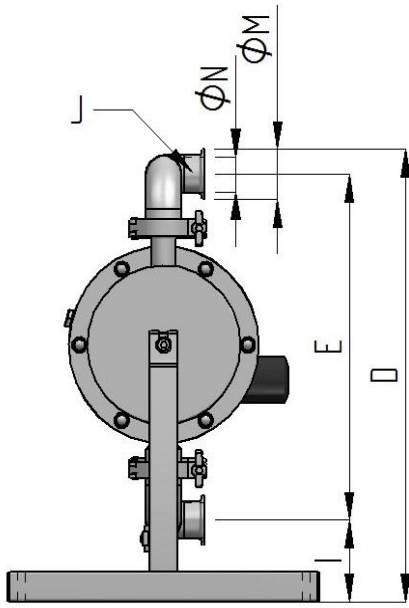
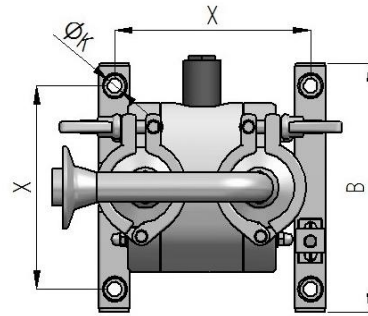

T80-825

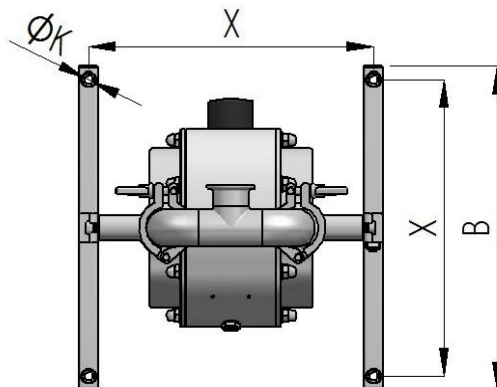
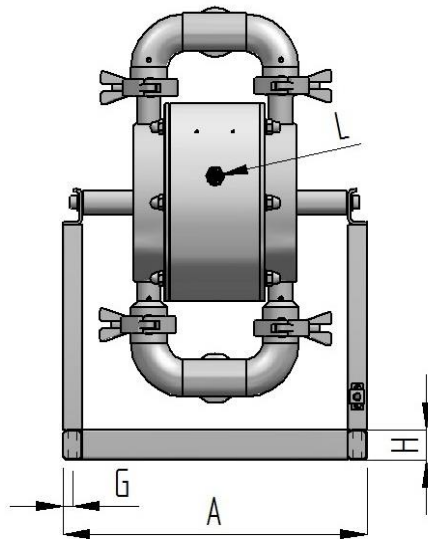

6. DATA

6.4. Technical data

TECHNICAL DATA	PUMP SIZE					
	T30	T80	T125	T225	T425	T825
Max capacity [l/min] / [US GPM]	28 / 7.4	78 / 20.6	159 / 42	340 / 89.8	590 / 156	830 / 219
Volume per stroke* [ml] / [cu in]	40 / 2.4	135 / 8.2	314 / 19.2	1000 / 61	2300 / 140	3281 / 200
Max discharge pressure [bar] / [psi]	8 / 116	8 / 116	8 / 116	8 / 116	8 / 116	8 / 116
Max air pressure [bar] / [psi]	8 / 116	8 / 116	8 / 116	8 / 116	8 / 116	8 / 116
Max suction lift dry** [m] / [Ft]	2 / 6.6	2.4 / 7.9	4 / 13	5 / 16	5 / 16	4 / 13
Max suction lift wet [m] / [Ft]	7 / 23	8 / 26	9 / 29.5	9 / 29.5	9 / 29.5	9 / 29.5
Max size of solids ø in [mm] / [in]	3 / 0.12	4 / 0.16 18 / 0.7***	6 / 0.24 18 / 0.7***	10 / 0.39 51 / 2***	15 / 0.59 51 / 2***	20 / 0.59 100 / 4***
Max temp. with EPDM [°C] / [°F]	90 / 194	90 / 194	90 / 194	90 / 194	90 / 194	90 / 194
Max temp. with NBR [°C] / [°F]	70 / 158	70 / 158	70 / 158	70 / 158	70 / 158	70 / 158
Max temp. with PTFE [°C] / [°F]	110 / 230	110 / 230	110 / 230	110 / 230	110 / 230	110 / 230
Weight [kg] / [lb]	5 / 11	8 / 18	11 / 24	21 / 46	35 / 77	133 / 293

* = Tested on PTFE diaphragms; using rubber diaphragms will increase the volume per stroke.

** = With stainless steel valve balls, other materials may reduce suction. Please consult us in this matter.

*** = Flap valve version.

COMPONENT	MATERIAL
Wetted metal details	Stainless steel AISI 316L electro polished
Liquid contact surfaces roughness	Ra < 1.6(Standard) Ra < 0.8 and 0.5 as option
Centre block (not wetted)	PP, PP conductive, aluminium
Diaphragms	PTFE, PTFE with white back, EPDM, white EPDM, , NBR white, NBR (non FDA)
Valve balls	PTFE, AISI 316, Ceramic, SiC, EPDM (non FDA, NBR (non FDA)
Air valve	Brass (std.), stainless steel AISI 316L or PET with NBR (std.), EPDM or FKM O-rings
Sealing (wetted)	PTFE or EPDM
Housing stud bolt	A4-80
Diaphragm shaft	Stainless steel AISI 316L (T30, T825) / 304L (T80 – T425)

6.5. Tightening torques

Checking of the tightening torques is necessary after periods of stoppage, when temperature variations are a factor or after transport and maintenance of the pump.

What is more for proper operation and safety the torque values should be checked frequently as part of preventive maintenance (contact Tapflo for interval proposals). Although pump applications vary, a general guideline is to re-torque the pump every two weeks.

Tightening torque [Nm]		
PUMP SIZE	Pos. 37 - Nut	Pos. 16 – Diaphragm screw
T30	5.5	-
T80	8	10
T125	16	13
T225	20	20
T425	23	22
T825	30	26

6.6. Permitted loads on manifolds

6. DATA

We recommend not to exceed the following loads and forces reacting on the manifolds.

T30		
Direction	Load [N] (inlet/outlet)	Moment of force (inlet/outlet) [Nm]
X	16,2	3,4
Y	16,2	3,4
Z	16,2	3,4

T825		
Direction	Load [N] (inlet/outlet)	Moment of force (inlet/outlet) [Nm]
X	93	13,2
Y	93	13,2
Z	93	13,2

T80		
Direction	Load [N] (inlet/outlet)	Moment of force (inlet/outlet) [Nm]
X	31	6,3
Y	31	6,3
Z	31	6,3

T125		
Direction	Load [N] (inlet/outlet)	Moment of force (inlet/outlet) [Nm]
X	35	7,3
Y	35	7,3
Z	35	7,3

T225		
Direction	Load [N] (inlet/outlet)	Moment of force (inlet/outlet) [Nm]
X	43	8,8
Y	43	8,8
Z	43	8,8

T425		
Direction	Load [N] (inlet/outlet)	Moment of force (inlet/outlet) [Nm]
X	56	11,5
Y	56	11,5
Z	56	11,5

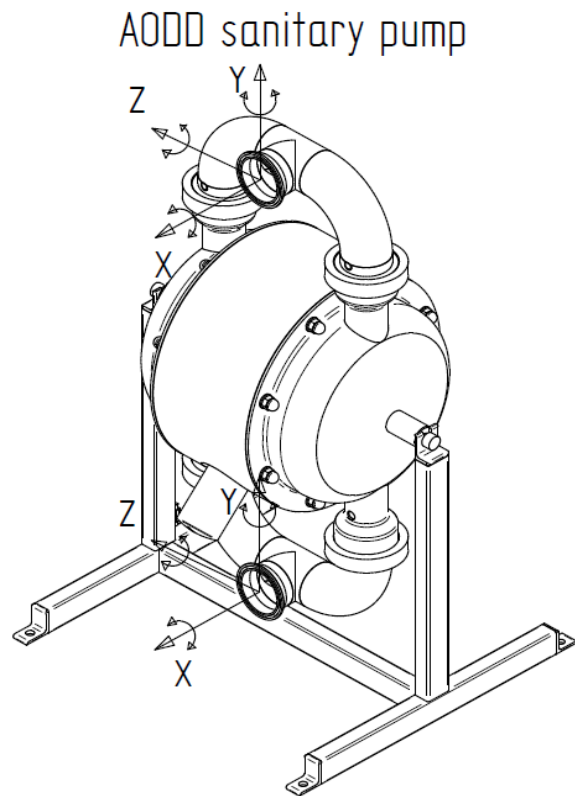

7. WARRANTY

7.2. Returning parts

When returning parts to Tapflo please follow this procedure:

- Consult Tapflo for shipping instructions.
- Cleanse or neutralize and rinse the part/pump. Make sure the part/pump is completely empty from liquid.
- Pack the return articles carefully to prevent any damage during transportation.

Goods will not be accepted unless the above procedure has been complied with.

7.3. Warranty

Tapflo warrants products under conditions as stated below for a period of not more than 5 years from installation and not more than 6 years from date of manufacturing.

1. The following terms and conditions apply to the sale of machinery, components and related services and products, of Tapflo (hereinafter "the products").
2. Tapflo (the manufacturer) warrants that:
 - a. its products are free of defects in material, design and workmanship at the time of original purchase;
 - b. its products will function in accordance with Tapflo operative manuals; Tapflo does not guarantee that the product will meet the precise needs of the Customer, except for those purposes set out in any invitation to render documents or other documents specifically made available to Tapflo before entering into this agreement;
 - c. high quality materials are used in the construction of the pumps and that machining and assembly are carried out to the highest standards.

Except as expressly stated above, Tapflo makes no warranties, express or implied, concerning the products, including all warranties of fitness for a particular purpose.

3. This warranty shall not be applicable in circumstances other than defects in material, design, and workmanship. In particular warranty shall not cover the following:
 - a. Periodic checks, maintenance, repair and replacement of parts due to normal wear and tear (seals, O-rings, rubber items, diaphragms, air valves etc.);
 - b. Damage to the product resulting from:
 - b.1. Tampering with, abuse or misuse, including but not limited to failure to use the product for its normal purposes as stated at the time of purchase or in accordance with Tapflo instructions for use and maintenance of the product, or the installation or improper ventilation or use of the product in a manner inconsistent with the technical or safety standard in force;
 - b.2. Repairs performed by non-skilled personnel or use of non-original Tapflo parts;
 - b.3. Accidents or any cause beyond the control of Tapflo, including but not limited to lightning, water, fire, earthquake, and public disturbances, etc.;

7. WARRANTY

4. The warrantee shall cover the replacement or repairing of any parts, which is documented faulty due to construction or assembling, with new or repaired parts free of charges delivered by Tapflo. Parts subjected to normal tear and wear shall not be covered by the warranty. Tapflo shall decide as to whether the defective or faulty part shall be replaced or repaired.
5. The warrantee of the products shall be valid for a period in accordance to the current law from the date of delivery, under the condition that notice of the alleged defect to the products or parts thereof be given to Tapflo in written within the mandatory term of 8 days from the discovery. Repair or replacement under the terms of this warranty shall not give a right to an extension to, or a new commencement of, the period of warranty.
6. Repair or replacement under the terms of this warranty shall not give a right to an extension to, or a new commencement of, the period of warranty. Repair or replacement under the terms of this warranty may be fulfilled with functionally equivalent reconditioned units. Tapflo qualified personnel shall be solely entitled to carry out repair or replacement of faulty parts after careful examination of the pump. Replaced faulty parts or components will become the property of Tapflo.
7. The products are built in accordance with standard CE normative and are tested (where applicable) by Tapflo. Approval and tests by other control authority are for the customer's account. The products shall not be considered defective in materials, design or workmanship if they need to be adapted, changed or adjusted to conform to national or local technical or safety standards in force in any country other than that for which the unit was originally designed and manufactured. This warranty shall not reimburse such adaptations, changes or adjustments, or attempt to do so, whether properly performed or not, nor any damage resulting from them, nor any adaptation, change or adjustments to upgrade the products from their normal purpose as described in the products operative manual without the prior written consent of Tapflo.
8. Installation, including electric and other connections to utility mains according to Tapflo drawings, is for the cost and responsibility of the customer, unless otherwise agreed in writing.
9. Tapflo will not be liable on any claim, whether in contract, tort, or otherwise, for any indirect, special, incidental, or consequential damages, caused to the customer or to third parties, including loss of profits, arising by any possible infringement of par. 3 above or by the customer or third parties being in the impossibility of using the products.

Steady the above, Tapflo liability to the customer or third parties from any claim, whether in contract, tort, or otherwise, shall be limited to the total amount paid by the customer for the product that caused the damages.

Sweden

Filaregatan 4 | S-442 34 Kungälv

Tel: +46 303 63390

Fax: +46 303 19916

E-mail addresses:

Commercial questions: sales@tapflo.com

Orders: order@tapflo.com

Tech support: support@tapflo.com

Tapflo products and services are available in 75 countries on 6 continents.

Tapflo is represented worldwide by own Tapflo Group Companies and carefully selected distributors assuring highest Tapflo service quality for our customers' convenience.

AUSTRALIA | AUSTRIA | AZERBAIJAN | BAHRAIN | BELARUS | BELGIUM | BOSNIA & HERZEGOVINA | BRAZIL | BULGARIA | CANADA | CHILE | CHINA | COLOMBIA | CROATIA | CZECH REPUBLIC | DENMARK | ECUADOR | EGYPT | ESTONIA | FINLAND | FRANCE | GEORGIA | GERMANY | GREECE | HONG-KONG | HUNGARY | ICELAND | INDIA | INDONESIA | IRAN | IRELAND | ISRAEL | ITALY | JAPAN | JORDAN | KAZAKHSTAN | KUWAIT | LATVIA | LIBYA | LITHUANIA | MACEDONIA | MALAYSIA | MEXICO | MONTENEGRO | MOROCCO | NETHERLANDS | NEW ZEALAND | NORWAY | POLAND | PORTUGAL | PHILIPPINES | QATAR | ROMANIA | RUSSIA | SAUDI ARABIA | SERBIA | SINGAPORE | SLOVAKIA | SLOVENIA | SOUTH AFRICA | SOUTH KOREA | SPAIN | SUDAN | SWEDEN | SWITZERLAND | SYRIA | TAIWAN | THAILAND | TURKEY | UKRAINE | UNITED ARAB EMIRATES | UNITED KINGDOM | USA | UZBEKISTAN | VIETNAM

Tapflo Group Companies

Australia

Tapflo Oceania (Pty) Ltd
Tel: +61 1800 303 633
sales@tapflo.com.au

Austria

Tapflo Austria
Tel: +43 732 27292910
sales@tapflo.at

Baltic States

Tapflo Latvia
Tel: +371 67472205
sales@tapflo.lv

Belarus

Tapflo Belarus
Tel: +375 17 3934609
sales@tapflo.by

Belgium

Tapflo Benelux B.V.
Tel: +31 (0)85 00 743 00
info@tapflo.nl

Bulgaria

Tapflo EOOD
Tel: +359 (0)2 974 18 54
office@tapflo.bg

Canada

Tapflo Canada
Tel: +1 514 813 5754
canada@tapflo.com

Croatia

Tapflo d.o.o.
Tel: +385 91 4884 666
sales@tapflo.hr

Czech Republic

Tapflo s.r.o.
Tel: +420 513 033 924
tapflo@tapflo.cz

China

Tapflo (Wuxi)
Tel: +86 510 8241 7072
sales@tapflo.cn

Denmark

Tapflo Danmark
Tel: +45 36 454600
info@tapflo.dk

France

Tapflo France
Tel: +33 1 34 78 82 40
info@tapflo.fr

Hungary

Tapflo kft.
Tel: +36 30 148 8551
office@tapflo.hu

India

Tapflo Fluid Handling India Pvt Ltd
Tel: +91 20 65000215
ac@tapflo.in

Ireland

Tapflo Ireland Ltd
Tel: +353 1 2011911
info@tapflo.ie

Italy

Tapflo Italia
Tel: +39 0362307698
info@tapfloitalia.com

Japan

Tapflo Japan K.K.
Tel: +81-3-6240-3510
tapflojp@tapflo.co.jp

Kazakhstan

Tapflo Kazakstan
Tel: +7 727 3278347
sales@tapflo.kz

Netherlands

Tapflo Benelux B.V.
Tel: +31 (0)85 00 743 00
info@tapflo.nl

Poland

Tapflo Sp. z o.o.
Tel: +48 58 530 42 12
info@tapflo.pl

Romania

S.C. Tapflo Rom. S.r.l.
Tel: +40 21 3451255
sales@tapflo.ro

Russia

Tapflo Company
Tel: +7 495 232 18 28
sales@tapflo.com.ru

Serbia

Tapflo d.o.o.
Tel: +381 21 44 58 08
sales@tapflo.rs

Slovakia

Tapflo s.r.o.
Tel: +421 911 137 883
tapflo@tapflo.sk

Slovenia

Tapflo GmbH
Tel: +386 68 613 474
sales@tapflo.hr

Spain

Tapflo Iberica
Tel: +34 91 8093182
avives@tapfloiberica.es

South Africa

Tapflo (Pty) Ltd
Tel: +27 31 701 5255
sales@tapflo.co.za

Turkey

Tapflo Makina Ltd
Tel: +90 216 467 33 11
sales@tapflo.com.tr

Ukraine

TOB Tapflo
Tel: +380 44 222 68 44
sales@tapflo.ua

Uzbekistan

Tapflo Uzbekistan
Tel: +998 712370940
sales@tapflo.uz

United Kingdom

Tapflo (UK) Ltd
Tel: +44 2380 252325
sales@tapflo pumps.co.uk

